

ENGLISH

User and Service Manual

Flyer[®]

Lightweight Tilt-In-Space Manual Wheelchair



READ INSTRUCTIONS BEFORE USING

SAVE THIS BOOK FOR FUTURE REFERENCE

 **Convaid**
by Etac

Customer Service Support

Toll Free: 1-844-US Mobility (844-876-6245)
Phone: (310) 618-0111
Fax: (310) 618-8811
Email: convaidsales.us@etac.com
International Email: international.convoid.us@etac.com
Website: www.etac.us.com

Technical assistance or repair information hours are:
Monday-Friday, 6 a.m. to 4:30 p.m. PST

Before Calling:

Please fill in the following. Customer Service will be able to help you more quickly if the information indicated below is readily available.

Serial number of chair: _____

Model of chair: _____

Date purchased: _____

Notice:

The information contained in this document is subject to change without notice.

No part of this document may be photocopied, reproduced, transmitted, transcribed, stored in a retrieval system or translated to another language or computer language, in any form or by any means, electronic, mechanical, magnetic, optical, chemical, manual or otherwise without the prior written consent of Convoid.

Use only Convoid accessories and parts on Convoid products. Convoid parts are not interchangeable with other manufacturers' products. Replace any worn parts immediately.

Table of Contents

Product Overview

Definition of Symbols	1
Warnings	3
Maintenance, Operating & Safety Instructions	8
Warranty	14
Flyer Standard Features Overview	15
Mobility Base Front and Back	16
Seating Module Standard - Front	17
Seating Module Standard - Back	18
Seating Module with Pans - Front	19
Seating Module with Pans - Back	20
Flyer Specifications	21
Annex A Information Disclosure	22

Setting Up

Contents in the Box	24
How To Remove Chair from Box	24
Preparing the Chair for Use	24
Tools Required	24
Unfolding the Chair	25
Folding/Unfolding the Seating Module	25
Lifting/Carrying the Seating Module	27
Lifting/Carrying the Mobility Base	27
Installing Seating Module onto Mobility Base	28
Removing Seating Module from Mobility Base	29

Fitting Guide

Seat Back Height	30
Back Height Adjustment	30
Seat Depth Adjustment	31
Seat Width Adjustment	34
Mobility Base Width	37
Mobility Base Width Adjustment	37
Tilt-In-Space Adjustment	37
Cross Tube Adjustment on Back Canes	38
Recline Adjustment	39
Positioning Belts	40
Pelvic Positioning Belts	40
Two-Point Positioning Belt	40
Back Pan Cam Locks Positioning	41
Seat Pan Positioning	42
Footplate Adjustment	43
Foot Positioners	44

Wheels

Wheel Specifications45
Wheel Lock Operation45
Removal & Installation of Rear Wheels46

Accessories

Head Support47
Adjustable Headwing Headrest Instructions48
Universal Headrest Bracket Installation Instruction48
Anatomic Headrest Installation49
Adjustable Headrest Installation51
Upper Extremity Support Surface (Tray)52
Height Adjustable Removable Armrests and Tray52
Calf Panel54
Laterals54
Swing-Away Laterals by R8256
Hip Guides57
Medical Knee Abductor (Pommel)58
Canopy Attachment59
Oxygen Tank Holder59
Attaching LTV Bracket59
LTV Vent Holder60
Elevating Leg Rest60
Ventilator/Suction/Hard Tray61
Rear Anti-Tip Tubes.63
Curb Tipper.63

Transit Models

Transit Option64
Transportation Mode Instructions65
Recommended Clear Zones In Vehicle68
Securing the Wheelchair68
Providing Clear Space & Padding71
Restraining the Wheelchair Occupant71
Using Postural Belts & Supports72
Trays & Other Wheelchair Components73
WTORS Manufacturers74

Troubleshooting Guide











Troubleshooting75
---------------------------	-----

READ BEFORE USE

Read the user's guide completely before use and fully understand its content. Familiarize yourself with the handling and functions of the product before use and practice them. Any caregiver that is going to operate this chair should also read the user's guide in full.

You are responsible for the safety of the user. The safety of the user could be affected if you do not follow the instructions in this user's guide. Nevertheless, not all possible circumstances and unpredictable situations can be covered by this user's guide. Reason, care, and circumspection are not features of the product; they are required of persons who use the product. If instructions are not clear and further explanation is necessary, please contact your Convaid provider. If you do not follow all instructions and warnings, serious injury or damage to the chair may occur. The latest version of all instructions and product safety notices are available on the Convaid website (www.etac.us.com) and can be printed in larger sizes. Additional video instructions are also available for reference purposes.

DEFINITION OF SYMBOLS

	<p>Indicates the need for the user to consult the instructions for use for important cautionary information such as warnings and precautions that cannot, for a variety of reasons, be presented on the medical device itself.</p>	 <p>This symbol is a mandatory marking for devices entering the European market to indicate conformity with the essential health and safety requirements set out in European Directives. The symbol may be accompanied by a four-digit identification number of the notified body. The vertical dimensions may not be less than 5 mm high.</p>
	<p>Indicates a medical device that need to be consulted with the instruction for user</p>	 <p>Indicates the Authorized representative in the European Community.</p>
	<p>This symbol indicates potential finger entrapment..</p>	 <p>This symbol indicates the manufacturer's catalogue number so that the medical device can be identified.</p>
	<p>This symbol indicates correct lifting points for safe moving and handling.</p>	 <p>Indicates the medical device manufacturer.</p>
	<p>This symbol indicates maximum user's weight.</p>	 <p>Indicates the date when the medical device was manufactured.</p>
	<p>Indicates the manufacturer's serial number so that a specific medical device can be identified.</p>	



This symbol indicates a wheelchair which cannot be used in motor vehicle as vehicle seat. This wheelchair does not comply with WC19 (RESNAWC-4:2012 for ISO7176-19:2008) and cannot be used as a vehicle seat to transport the user in a vehicle.



The Symbol indicates a wheelchair which can be used in motor vehicle as vehicle seat. This wheelchair complies with WC19 (RESNAWC-4:2012 and ISO 7176-19:2008) and can be used as a vehicle seat to transport the user in a vehicle.



This symbol indicates the position of an anchor point when using a 4-point tie down system (WTORS) during transit.



This symbol indicates conformity with RESNA WC-4 Section 19 requirements.

CHOOSE THE RIGHT CHAIR & SAFETY OPTIONS

There are several options available to meet the needs of the wheelchair user. Make sure that your (and your health care provider's) choice of chair and other added options takes into account the user's comfort, positioning, physical limitations, and hazards that may be encountered during daily use. Operating the manual wheelchair outside of the recommendations provided by the manufacturer can lead to a dangerous situation.

The wheelchair is not suitable for jogging, running, skating or similar activities. Swiveling front wheels tend to wobble at higher speeds and can cause a sudden stop, and the wheelchair can tip over. Use the wheelchair only at regular walking speed. Under no circumstance should you let go of the push handle while pushing.

The durability of this product is five years when it is used with proper care and maintenance according to the user's guide.

Final selection of the type of device and any accessories or adjustments rests solely with the user and their health care provider. Some important factors to consider when choosing a configuration include, but are not limited to:

1. The user's disability, strength, balance, coordination, and ability limitations.
2. Neurological and orthopedic needs of the user.
3. Behavioral factors such as maturity and psychosocial development.
4. All factors should be considered when choosing a chair configuration as this can affect performance and function of the chair.

Indications for Use

The Convaid Flyer models are manual wheelchairs; they are intended to provide mobility to persons with disabilities who are partially or permanently non-ambulatory and limited to a sitting position.

In addition, the Flyer transit models have been tested and comply with the requirements of RESNA WC 4 Section-19:2012, "Wheelchairs used as seating in a motor vehicles".

Intended Use

Convaid's Flyer series are a lightweight ridge high-strength aluminum and steel manual wheelchair base with a removable mobility seating system for everyday indoor and outdoor use on flat firm terrain. These persons typically have some form of neuromuscular disorder that limits their ability to self-propel such as Cerebral Palsy.

Note: The end user of all Convaid attendant propelled wheelchair products is not determined by age but by body dimensions and mass. Please read and follow all warnings carefully to insure the safety of the user.

General Warnings



WARNING: The operator/caregiver must read and understand this manual prior to operating this equipment. If you are unable to understand any part of this manual, contact your supplier for assistance.



WARNING: The weight carried by the Flyer chair must never exceed the total weight capacity of:

<u>Cane Position</u>	<u>Transit Weight Capacity</u>	<u>Non-transit Weight Capacity</u>
1	85 lbs./39 kg	85 lbs./39 kg
2	170 lbs./75 kg	170 lbs./75 kg
3	170 lbs./75 kg	170 lbs./75 kg
4	170 lbs./75 kg	170 lbs./75 kg

NOTE: Weight capacity equals maximum occupant size plus any items carried. When using the chair in transit, all non-medically necessary devices must be removed from the chair and secured separately.



WARNING: When the back cane is factory set to position 1 the total weight carried by the Flyer must never exceed 85 lbs (39 kg).



WARNING: To reduce the risk of an accident:

- ALWAYS carefully read the User's Guide and become comfortable with operating the chair.
- ALWAYS watch for obstacles and avoid them as often as possible.
- MAKE SURE that the chair operates properly. Repair any problems before use.
- ALWAYS verify that the quick-release axles are locked so that the back wheels do not come off.
- ALWAYS secure the user into the chair during use.



WARNING: Positioning belts should never be used as a safety restraint device in a motor vehicle when transporting chair with occupant. An additional WC19 compliant automotive type seat belt is required when the chair is used in transport vehicles.



WARNING: Changes & Adjustments

Adjustments made to the chair may change the balance and function of the chair and may increase risk of tip over. Consult the Convaid Service Dealer before making adjustments.



WARNING: No modifications may be made to the mobility base or seating module, including but not limited to:

- Drilling holes
- Removing rivets

Warranty will be voided if modifications that change the structure of the mobility base and/or seating module of the chair are made without manufacturer's authorization.





WARNING: Unauthorized modifications may cause a safety hazard. If the warning is ignored, damage to your chair, and the potential severe injury of the person using the chair for unintended purposes, can occur.



WARNING: The chair should only be used on flat, firm terrain.

 **WARNING:** Use caution if performing stretching exercises, or any activity that results in leaning, as this may cause the chair to tip over.

 **WARNING:** Do not go up or down stairs without the assistance of another person or with user in the chair. If devices such as ramps or elevators are available, please use them. If they are not available, then the chair should be carried over the obstacle by two people without the user in the chair.

 **WARNING:** Pay particular attention when on slopes and inclines to prevent the user from:

- Falling out of the chair.
- The chair from tipping over.
- The chair from rolling away.

 **WARNING:** Before removing the user from the chair and before returning the user to it, always engage the wheel locks. Never remove or place user without engaging the wheel locks.

 **WARNING:** Never leave the user unattended in the chair even when they are strapped in and the wheel locks are engaged.

 **WARNING:** Do not stand on the foot support when getting in or out of the chair.

 **WARNING:** When the user reaches for objects in front, to the side, or behind the chair, be sure that they do not lean out of the chair too far since the shift in the center of gravity might cause the chair to tilt or tip over.

 **WARNING:** Please keep packaging material away from children. Plastic packaging presents the danger of suffocation.

 **WARNING:** The chair is only intended to carry one user at a time. Do not carry more than one user at a time.

 **WARNING:** Whenever you change a setting on the chair, make sure that you firmly tighten any screws or knobs that have been loosened prior to placing the user in the chair.



WARNING: Do not perform wheelies as they may affect the center of gravity and cause the chair to tip over.



WARNING: Motor vehicle safety – The seating module is not designed, tested or intended to be used as a car seat. Never use the seating module as a car seat. Transfer the user from the chair to an approved motor vehicle adaptive car seat. If your chair is equipped with the transit option, refer to the transit section in this manual regarding use of this chair for transit.



WARNING: Never use this chair on an escalator because the chair may tip over.



WARNING: Many of the screws, bolts, and nuts used on this chair are specialized or high-strength fasteners. Only use fasteners purchased through Convoid or a Convoid service dealer.



WARNING: During transit, the chair must be forward facing with all non-medically necessary accessories removed.



WARNING: The chair could lose its flame resistant characteristics when using aftermarket seating or cushion.



WARNING: Do not leave or store the chair in direct sun/heat over a long period of time. Check the temperature of the chair prior to usage.



WARNING: When transferring the user from the chair:

- Work with your health care advisor to learn safe transfer and lifting methods.
- Have someone help you until you know how to do a safe transfer of the dependent on your own.
- Move your user's mobility device as close as you can to the location you are transferring to.
- Rotate the front casters until they point forward.
- Engage the parking brake before you transfer. This keeps the device stable during the transfer.
- When transferring a user into the device, make sure they are placed as far back onto the seat surface as possible. This will reduce the risk that the mobility device will tip over and/or move away from you.



WARNING: If the user reaches or leans it will affect the center of balance of the mobility device. This may cause a fall or tip over.



WARNING: NEVER allow the user to reach or lean if they must rise up off their seat for the action.



WARNING: If the user must reach, move the mobility device as close as you can to the object, and rotate the front casters until they are as far forward as possible.

Note: To do this: Move your mobility device past the object that the user might want to reach, then back up alongside it.



WARNING: The Upper Extremity Support Surface (Tray) with Flip-Up Armrests are not recommended to be used during transportation.

Important Information

Maintenance, Operating & Safety Instructions

- READ ALL INSTRUCTIONS BEFORE USING THE PRODUCT
- ALWAYS FOLLOW THESE SAFETY INSTRUCTIONS
- SAVE SAFETY INSTRUCTIONS FOR FUTURE REFERENCE

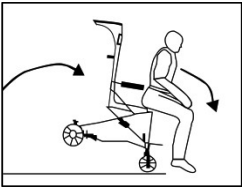

Fig. 1

- For user safety, the seat belt should be fastened at all times.
- Do not leave user unattended.
- Do not strap user too tight.
- Always apply wheel locks before letting go of the chair.
- If front edge of seat is at or forward of the point where tires touch the floor, avoid using front of seat tubes for support during entry or exit from chair to prevent tipping.
- Avoid using foot supports for weight support during exit or entry of the chair.

Waste Disposal

The shipping carton should be kept for possible return to the manufacturer/service facility for repair or maintenance. Other paper packaging waste should be set aside for recycling. For disposition of replaced parts or the complete chair, the materials should be separated into: plastic, rubber, steel, aluminum, etc., and set aside for recycling.

Suitable Environment

The chair is intended for both indoor and outdoor use. If the chair is used in the rain, the excess water should be wiped off with a soft cloth. If the chair is splashed with mud or corrosive substances like salt water or road salt, the chair should be washed clean with water, wiped dry and a hypoallergenic and biodegradable lubricant reapplied to the moving parts. Contact with seawater should be avoided, as it will corrode areas that cannot be washed clean. When going from outside to inside, clean any excess dirt or mud from the wheels to prevent soiling of inside environment.

Safety Instructions

- Follow folding/unfolding instructions.
- Never leave occupied chair unattended.
- Do not attempt to take occupied chair up or down stairs, escalators, steep inclines, icy or slippery surfaces.
- When transferring user to or from chair, apply wheel locks.
- To avoid tipping, do not overload the chair, or hang heavy items on the push handles.
- Frequently inspect the adjustments on the frame and the positioning accessories (see maintenance chart).

IMPORTANT INFORMATION

- Do not use chair after occupant has outgrown it.
- Do not ignore minor malfunctions and maintain the chair in good operating condition. Monitor the wheel locks (brakes) regularly (see maintenance chart).
- If and whenever possible and feasible, the rider should transfer out of the chair and into an approved vehicle seat and passenger restraint system.
- However, if a transfer is not possible, use only WC19 compliant chairs in a moving vehicle which contain the Wheelchair Tiedown and Occupant Restraint Systems (WTORS).
- Work with your health care advisor to learn safe transfer and lifting methods.
- Have someone help you until you know how to do a safe transfer of the dependent on your own.
- Move your user's mobility device as close as you can to the location you are transferring to.
- Rotate the front casters until they point forward.
- Engage the parking brake before you transfer. This keeps the device stable during the transfer.
- When transferring a user into the device, make sure they are placed as far back onto the seat surface as possible. This will reduce the risk that the mobility device will tip over and/or move away from you.

 **WARNING:** If the user reaches or leans it will affect the center of balance of the mobility device. This may cause a fall or tip over.

 **WARNING:** NEVER allow the user to reach or lean if they must rise up off their seat for the action.

 **WARNING:** If the user must reach, move the mobility device as close as you can to the object, and rotate the front casters until they are as far forward as possible. **Note:** To do this: Move your mobility device past the object that the user might want to reach, then back up alongside it.

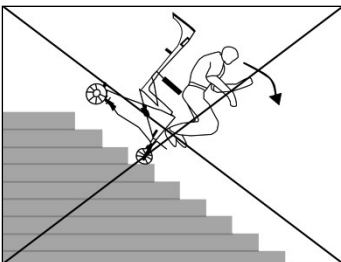

Fig. 2

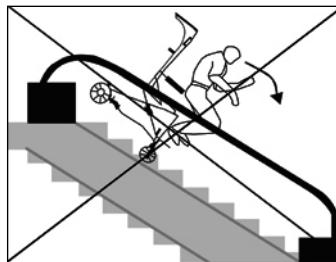

Fig. 3

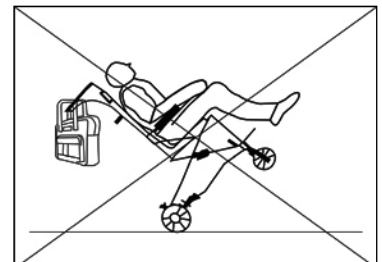

Fig. 4

IMPORTANT INFORMATION

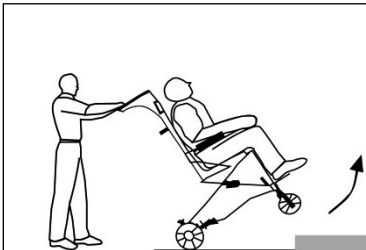

Fig. 5

When going up a curb or step, face forward and tilt the chair back to lift the front wheels over the curb. Move forward and lift the rear wheels over the curb. The Flyer curb clearance is 2.5" (63.5mm), the curb clearance with the storage basket is 2.2" (64mm). **Fig. 5**

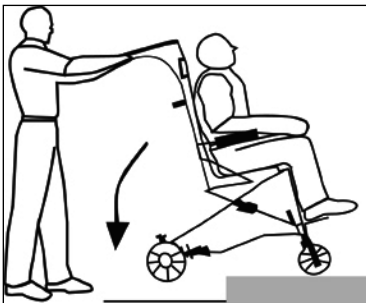

Fig. 6

When going down a curb, approach the curb backwards. Lower the rear wheels down the curb and continue backwards, taking the weight off the front wheels so they can be gently lowered. **Fig. 6**

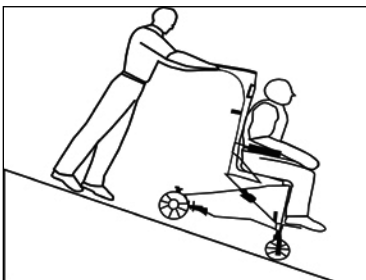

Fig. 7

Maintain control of the chair at all times while going up/down ramp. Avoid steep slopes, particularly with a heavy occupant. If in doubt, do not proceed unless a third party is present to help maintain control of chair. **Fig. 7**

User Maintenance

The following maintenance procedures should be conducted on a regular basis: examine your Convaid product visually from time to time for possible wear and tear. Teflon™ spray* should be applied to frame and moving parts to maintain easy folding and adjustment.

- a) Axles and Moving Parts: Axles and moving parts should be wiped off weekly with a slightly moist cloth, to remove dust, dirt and mud. Sparingly apply a high quality Teflon™ spray* after each cleaning.
- b) Do not use WD-40, silicone sprays or other lubricant sprays as they will attract dust and dirt.
- c) Repair or replace loose, worn, bent, missing or damaged parts before using the chair!

* Use a non-toxic, hypoallergenic lubricant for all moving parts of the frame.

IMPORTANT INFORMATION

Check for functionality and/or damage of the following:	Weekly	Every 3 months	Every 6 months	As necessary
Rims and tires	•			
Wheel lock and hand brakes	•			
Accessories	•			
Front and rear wheel axles	•			
Cleaning & lubricating all moving parts*	•			
Belts, zippers and Velcro® closures		•		
Seat/back upholstery**/tautness		•		
Armrests & foam (cushioned parts)			•	
Frame			•	
Contacting a Convaid Dealer for service or repair***				•

* Use a non-toxic, hypoallergenic lubricant for all moving parts of the frame. **Do NOT use WD-40 or other silicone based spray as a lubricant.**

** Follow cleaning instructions for appropriate user hygiene.

*****NOTE:** Repair or replacement of non-removable, worn or broken parts must be performed by a qualified service facility.

Cleaning and disinfection

To prevent the spread of germs, clean all skin contacting areas with disinfectant wipes regularly. Keep frame dry and apply a non-toxic, hypoallergenic and biodegradable lubricant to all moving parts. After longer storage periods, and before further use, the entire chair needs to be serviced, cleaned, and disinfected.

Cleaning of frame

Frame is to be kept dry and free of dirt and should be wiped off with a non-toxic, hypoallergenic and biodegradable wipe. Lubricant should be applied to moving parts as needed to maintain easy folding and adjustment.

Corrosive substance such as salt water should be avoided at all times. If exposed the frame should be wiped off with a moist towel as soon as possible. Water and a soft cloth are sufficient for basic cleaning.

Cleaning of wheels and brakes

Wheels and brakes should be kept free of dirt or mud after each use. Foreign objects could cause interference with moving parts. Wipe wheels and brakes with a moist cloth as needed and readjust brakes if needed.

IMPORTANT INFORMATION

Cleaning of fabric cover

Seat and back upholstery can be easily removed, washed, air dried and reattached to the chair. Use standard detergent to wash fabric.

Cushioned parts can also be removed from chair, washed or wiped off with a moist cloth. Before reattaching them to the chair, make sure they are completely dry. Use mild detergent to wash fabric. Use gentle cycle and cold water. Hang Dry.

Parts that are permanently attached may be wiped thoroughly with a moist cloth. Allow sufficient time to dry before placing user in chair.

Storage

Store your chair in a clean, dry area and avoid extended exposure to heat or moisture. After extended storage periods, and before reuse, the entire chair needs to be serviced, cleaned and disinfected.

Re-use

Your Convaid chair should undergo wipe-down disinfection before re-use.

Please use a non-toxic, biodegradable disinfectant solution suitable for surface disinfection. Please check the following components for intactness before operation (see MAINTENANCE CHART).

Repair or replace if necessary:

- Wheels (tread pattern), air pressure if applicable
- Frame
- Seat and back upholstery
- Wheel lock operation
- Bearings and axles: check wear and tear/lubrication
- Straight-running stability of wheels attachments

Repairs

Caregiver/Dealer: The caregiver or dealer can replace easily removable parts or accessories, e.g. foot supports, heel loops, all fabric items, hand grips, etc.

Manufacturer/Service Facility: Repair or replacement of permanently attached, worn or broken parts must be performed by a qualified service facility. Any individual part of the chair can be replaced. Contact the manufacturer/service facility for needed repairs. The chair should be packaged in the original or suitable shipping carton for return to the manufacturer/service facility. Ship via UPS.

Tools Required

- Tools needed include 3/8", 7/16", 3/8" or 2 adjustable wrenches with 3/4" capacity, Phillips head screwdriver 5/32"
- Allen wrench (included)

Spare Parts

If you need any spare parts for your chair, please visit or call the Convoid service dealer you purchased this chair from. If the part is not under warranty, you will receive an estimate of the cost and, if necessary, shipping instructions for the return of the chair for repairs.

Functional Tests

All four wheels should make contact with the floor. With the chair empty, push it forward on a smooth level surface with enough momentum to travel six feet (2 m). The chair should not veer to the left or right more than six inches (150 mm). Wheels should be free running. Following the fold/unfold instructions; the chair should fold/unfold smoothly without undue effort. All fasteners should be secure. Fasteners on moving joints should not be overtight. Seat fabric should not be wide-stretched or sagging. Positioning accessories should be correctly adjusted and secure.

Convoid Service Dealer

Please record the Convoid Dealer from which you purchased your chair:

Company: _____

Address: _____

Phone: _____ Website: _____

Contact: _____ Email: _____

Serial #: _____

Or contact Convoid Customer Service at
844 US Mobility (844-876-6245) (+1-310-618-0111) or
convoidsales.us@etac.com

Warranty

Convaid warrants to the original retail purchaser of the Convaid product, that if any part thereof proves functionally defective in material or workmanship within the specified warranty period, such defective part will be repaired or replaced (at Convaid's discretion) free of charge. Warranty service may be performed by Convaid service center or (at Convaid's discretion) the factory.

Warranty Period (USA only)

Frame.....Lifetime of original retail buyer
Other components.....One year
Fabric & webbing.....One year

This warranty does not cover normal wear and tear or damage caused by accident or misuse. To exercise this limited warranty, the user should first obtain a Return Authorization Form from convaid.com. The product must be delivered charges pre-paid (UPS recommended) to the factory or to an authorized service center, together with a copy of the original invoice, and the Return Authorization Form.

THIS LIMITED WARRANTY EXCLUDES ANY CLAIM FOR INCIDENTAL OR CONSEQUENTIAL DAMAGES. ANY IMPLIED WARRANTY APPLICABLE IS LIMITED TO THE DURATION OF THIS WRITTEN WARRANTY. SOME STATES DO NOT ALLOW THE EXCLUSION OR LIMITATIONS OF INCIDENTAL OR CONSEQUENTIAL DAMAGES OR LIMITATIONS ON HOW LONG AN IMPLIED WARRANTY LASTS, SO THE ABOVE LIMITATIONS OR EXCLUSIONS MAY NOT APPLY TO THE USER. THERE ARE NO WARRANTIES WHICH EXTEND BEYOND THE DESCRIPTION ON THE FACE THEREOF. This warranty gives the user specific legal rights and the user may have other rights that vary from state to state. Warranty applicable in USA only, may vary in other countries.

Flyer Standard Features Overview

2 Seating System Options:



Fig 8: Solid Back with Convaid Seating Cushions



Fig 9: Back Canes Only (for After Market Seating)

Mobility Base

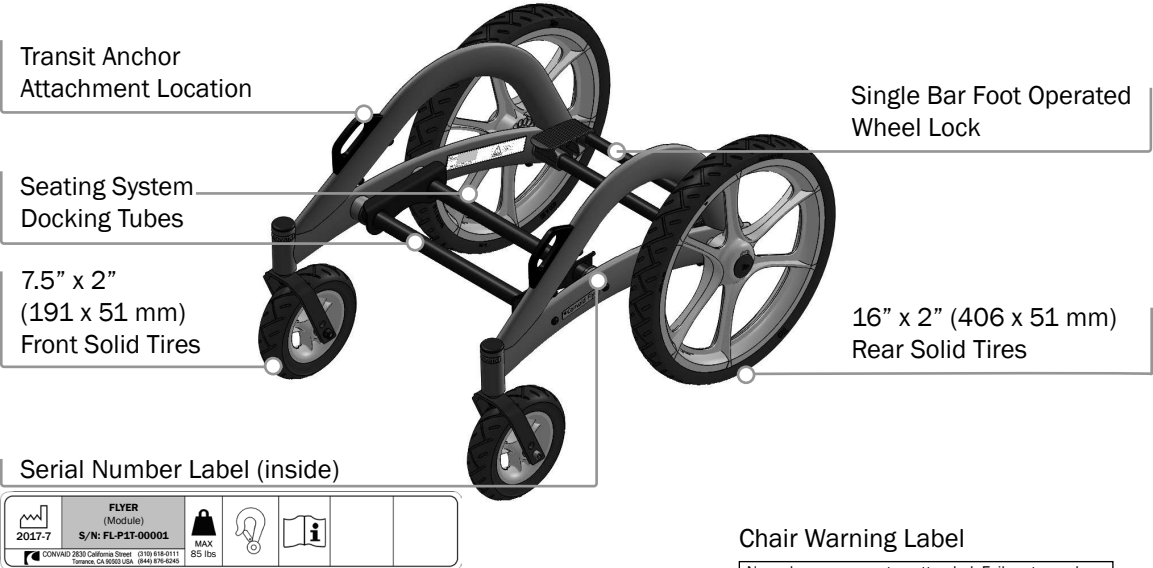

Fig. 10

Chair Warning Label

Never leave occupant unattended. Failure to read and follow user guide instructions could result in serious injury. To obtain a replacement user's guide email convaidsales.us@etac.com or call 844-876-6245.

Mobility Base Front and Back

Fig. 11 Option 1: 7.5" Front, 16" Rear Solid Tire

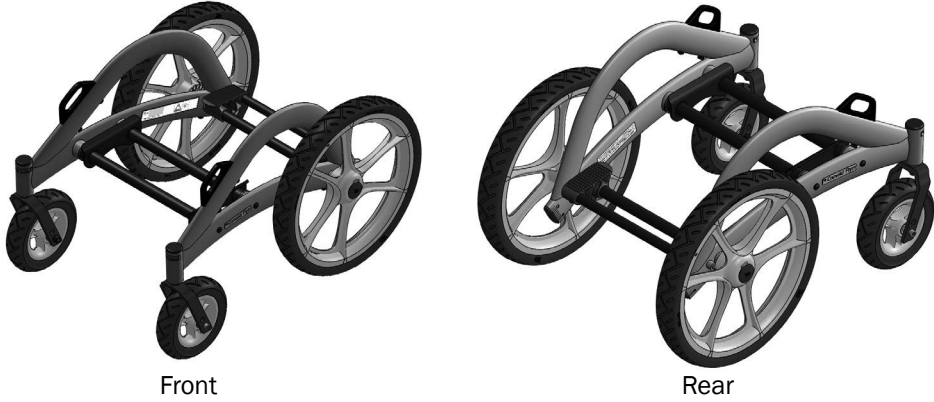

Fig. 12 Option 2: 6" Front, 11.5" Rear Solid Tire

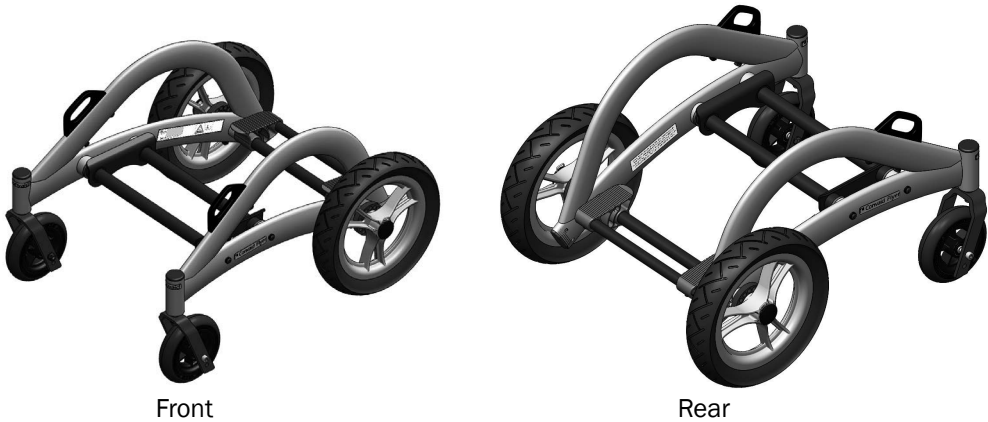
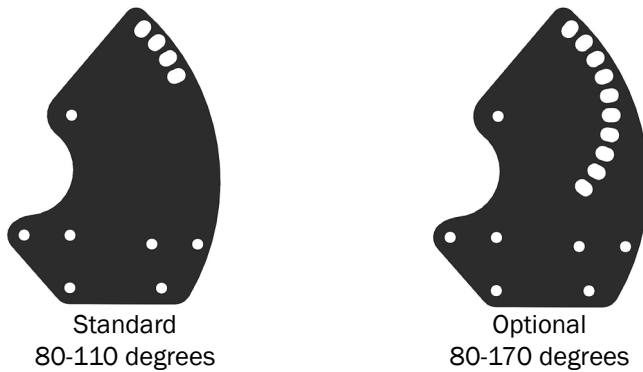

Fig. 13 Recline Options



Seating Module Standard - Front

Fig. 14

Tilt Adjustment Lever

Seating Module Back Crossbar

Recline Adjustment Cord

Tilt Cable

Recline Lock Pins

Transit Anchor

Individual Fixed Footplates

90° Removable Front Riggings

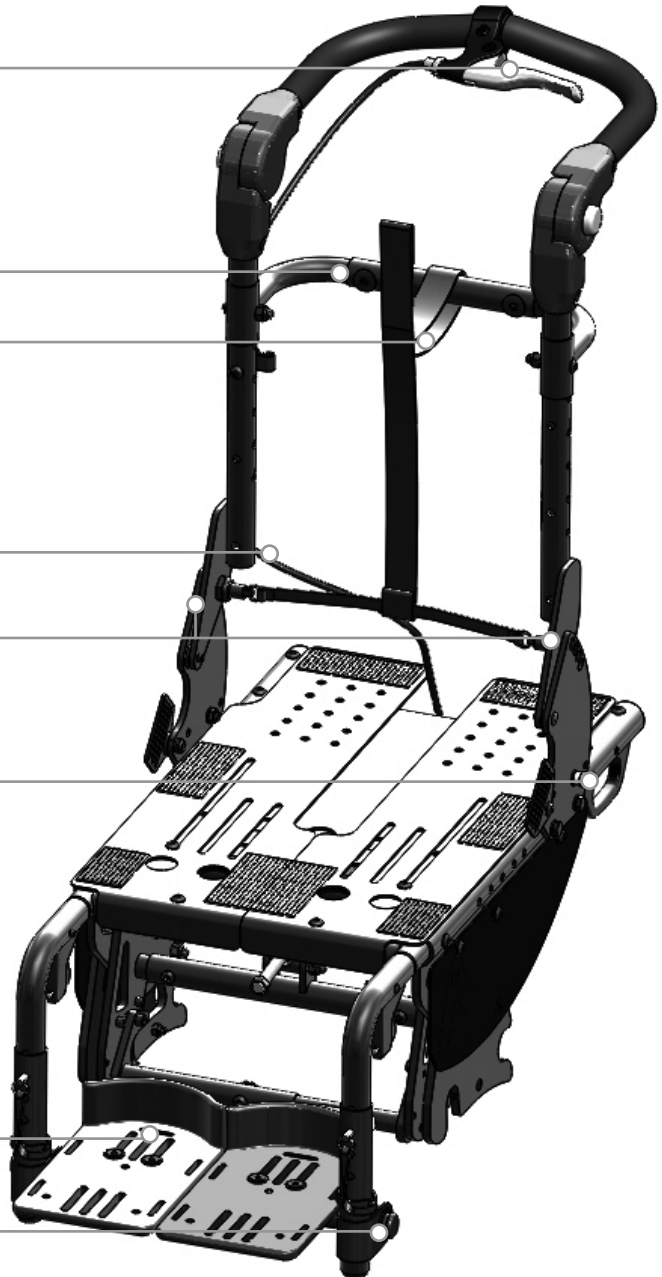

Seating Module Standard - Back

Fig. 15



Seating Module with Pans - Front

Fig. 16

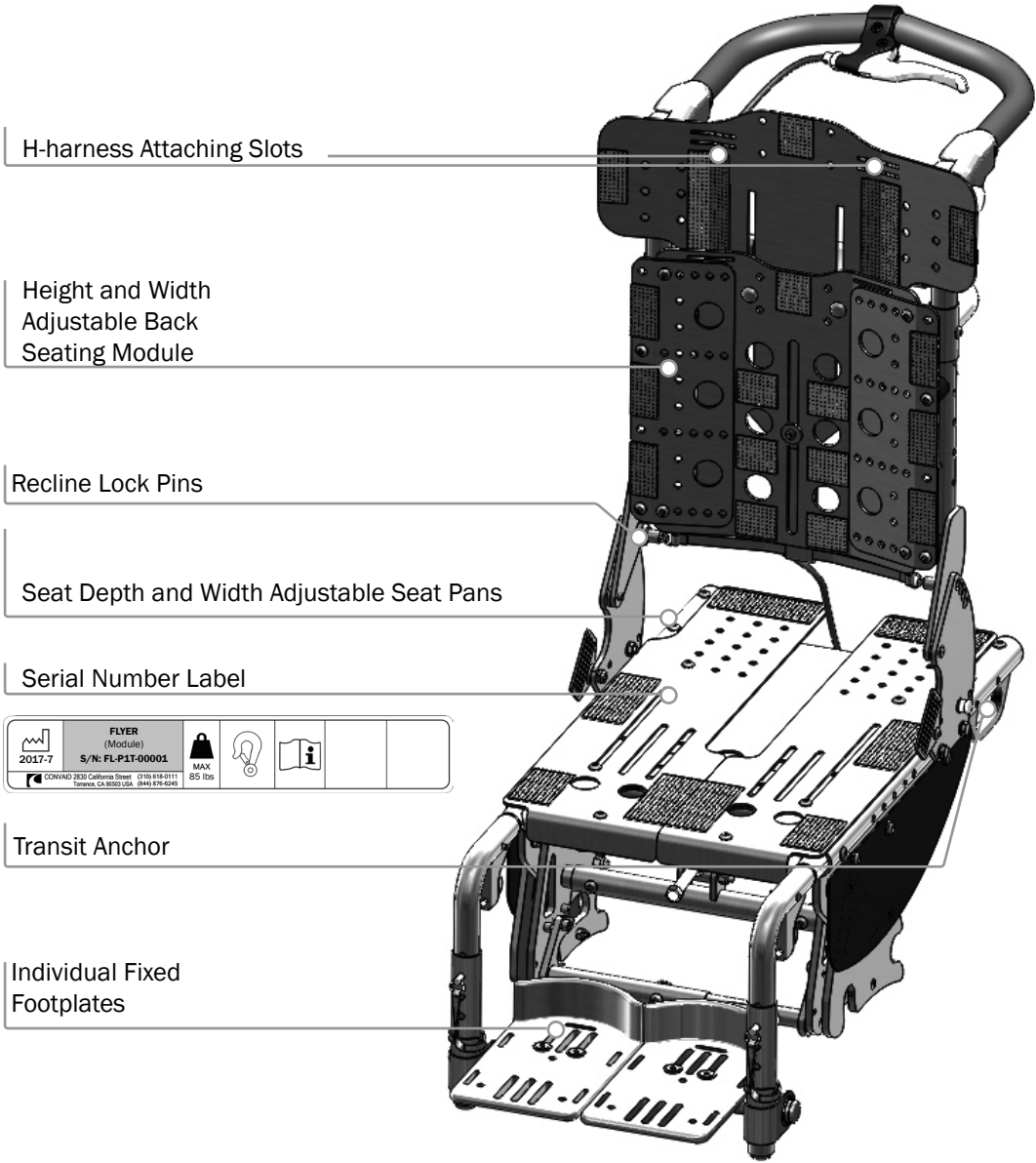

H-harness Attaching Slots

Height and Width Adjustable Back Seating Module

Recline Lock Pins

Seat Depth and Width Adjustable Seat Pans

Serial Number Label

 2017-7	FLYER (Module) S/N: FL-P1T-00001	 MAX 85 lbs			
<small>CONVAID 2630 California Street (310) 618-9111 Torrance, CA 90503 USA (844) 878-6245</small>					

Transit Anchor

Individual Fixed Footplates

Seating Module with Pans

Fig. 17

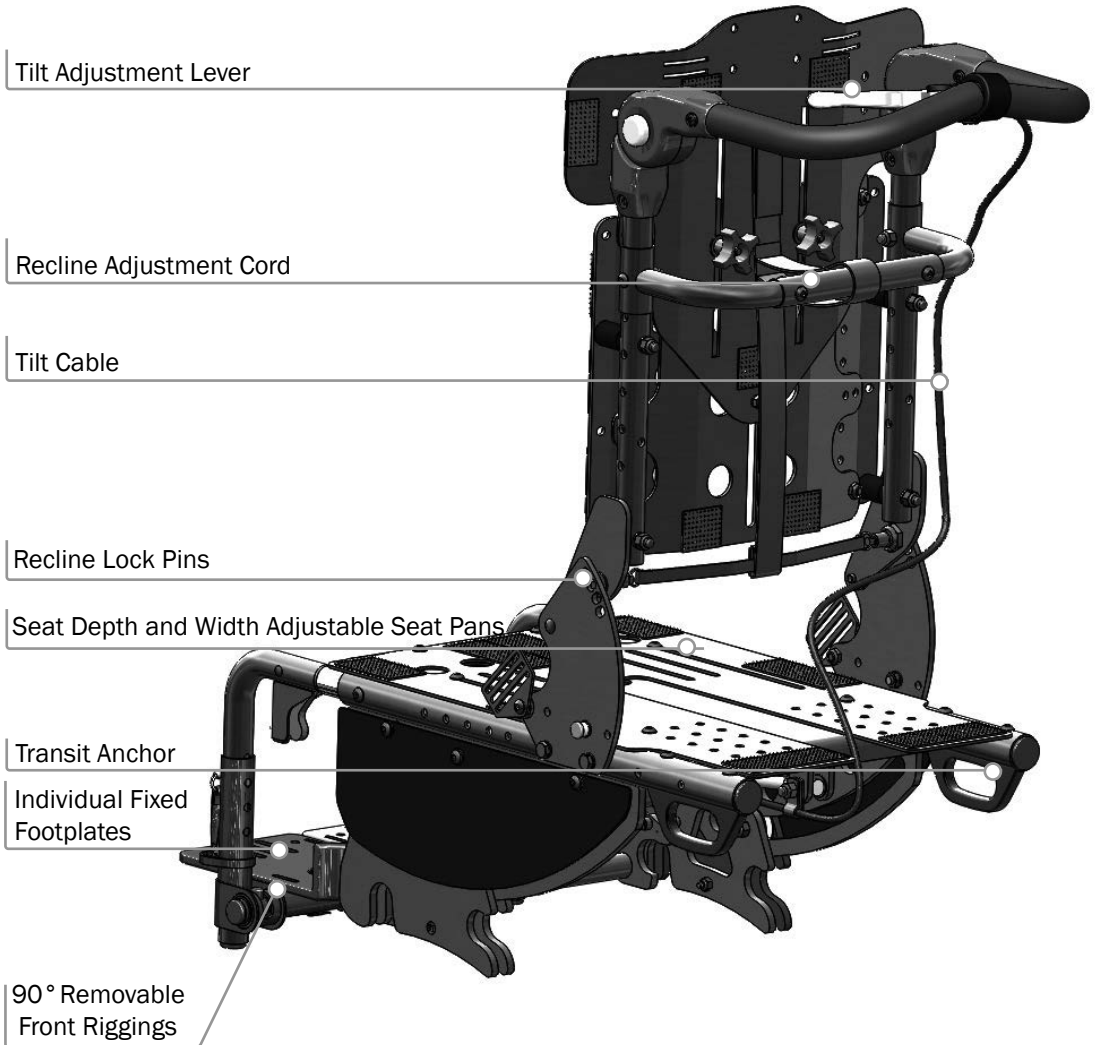

FLYER SPECIFICATIONS (Inches/Millimeters)

Model Size	FL 12	FL 13	FL 14	FL 15	FL 16
Seat Width	12/305	13/330	14/356	15/381	16/406
Seat Depth Options	Total available seat depth range is 11 - 21/279 - 533; customer to select range setting based on back cane position; each seat depth has 4/102 of growth.				
Seat Back Height Options	3 back cane height options to achieve 19/483, 22/559 and 25/635 with back pans, range is 13 - 25/330 - 635				
Seat to Footplate Elevating Legrest	9 - 14/ 229 - 356	9 - 14/ 229 - 356	11 - 16/ 279 - 406	11 - 16/ 279 - 406	13 - 18/ 330 - 457
Seat to Footplate Elevating Legrest with flipped footplates	5.25 - 11.25/ 133.35 - 285.75	5.25 - 11.25/ 133.35 - 285.75	7.25 - 13.25/ 184 - 336.5	7.25 - 13.25/ 184 - 336.5	9.25 - 15.25/ 235 - 387.35
Seat to Footplate Standard 90° Fixed	Range is 6 - 11.5/152 - 292				
Seat to Floor	2 wheel options provide 15/381 and 17/432 STF				
Seat to Back Angle	80 - 110° (std)				
Back Recline	80 - 170° (option)				
Tilt Range	-5° (forward) to 40° (rear)				
Overall Height 15" STF/17"STF	34 - 40/ 864 - 1016 (3/76 increments)	36-42/ 914 - 1067 (3/76 increments)	Height varies based on selected back cane height and selected seat to floor height		
Overall Length	25.75/654 size 1	28/711 size 5	Varies based on selected tires		
Overall Width	21/533	22/559	23/584	24/610	25/635
Folded Length	25.75/654 size 1	28/711 size 5	Varies based on selected tires		
Folded Width	21/533	22/559	23/584	24/610	25/635
Folded Height	Varies based on selected tires, 21.5 - 23.5/546 - 597				
Headrest Extension	22/559	25/635	28/711	Varies based on back cane height selection	
Shoulder Strap Height	17/432	20/508	23/584	Varies based on back cane height selection	
Push Handle Adjustments	±9/229 after selecting back cane size				
Weight Capacity (Regular)	Back Cane Position 1: 85 lbs/39 kg. Back Cane Positions 2 - 4: 170 lbs/75 kg.				

FLYER SPECIFICATIONS (Inches/Millimeters)

Weight Capacity (Transit)	Back Cane Position 1: 85 lbs/39 kg. Back Cane Positions 2 - 4: 170 lbs/75 kg.
Weight of Chair (varies based on tires)	11.5/305 tires: 30.7 lbs/14 kg. (mobility base = 13.9 lbs/6.3 kg., seating system with leg rest = 16.8 lbs/7 kg.) 16/406 tires: 34 lbs/15 kg. (mobility base = 17 lbs/7.7 kg., seating system with leg rest and footplate = 16.8 lbs/7.6 kg.)
Material (mobility base)	Steel/Aluminum
Material (plastic parts)	Fiber glass strengthened polyamide
Material (cushion)	Fire-resistant foam*
Material (fabrics)	Fire-resistance nylon, polyester*

* Resistance to ignition of upholstered parts complies to BS-EN 1021-1 and -2

RESNA WC-1 Annex A Information Disclosure

Wheelchair Model:	Flyer Series	Wheelchair Type:	Manual	
Maximum Occupant Mass:	170 lbs. / 75 kg.			
Name and Address of Manufacturer: Convaid Products 2830 California Street Torrance, CA 90503				
Disclosure Information (RESNA)	Standard Reference		Minimum Value	Maximum Value
	Section	Clause		
Static Stability Forward - Wheels Unlocked	1	9.2	10.6°	41°
Static Stability Rearward - Wheels Unlocked		10.26	13°	37°
Static Stability Rearward - Wheels Locked		10.3	10°	28°
Static Stability Anti-Tip - Wheels Unlocked		11.2	19°	33°
Static Stability Sideways - Wheels Unlocked		12.1	17°	27°
Overall Length	5	8.2	654.05 mm	
Overall Width		8.3	533.4 mm	635 mm
Stowage Length		8.5	654.1 mm	
Stowage Width		8.6	533.4 mm	635 mm
Stowage Height		8.7	546.1 mm	
Total Mass		8.9	13.2 kg	
Mass of Heaviest Part		8.10	7 kg	
Pivot Width		8.11	1193.8 mm	
Required Width of Right Angled Corridor		8.15	914.4 mm	

RESNA WC-1 Annex A Information Disclosure

Disclosure Information (RESNA)	Standard Reference		Minimum Value	Maximum Value
	Section	Clause		
Seat Plane Angle	7	7.3.2	-5°	40°
Effective Seat Depth		7.3.3	393.7 mm	647 mm
Effective Seat Width		7.3.4	304.8 mm	406.4 mm
Seat Surface Height at Front Edge		7.3.6	381 mm	
Back Support Angle		7.3.7	-10°	20°
Back Support Height		7.3.8	482.6 mm	
Foot Support to Seat		7.3.12	147.3 mm	279.4 mm
Leg To Seat Surface Angle		7.3.16	90°	
Arm Support Height		7.3.17	228.6 mm	342.9 mm
Front Location of Arm Support Structure		7.3.23	254 mm	
Propelling Wheel Diameter and Size Including Width		7.3.25		
Horizontal Location of Axle		7.3.26	4.3 mm	

Static Impact and Fatigue Testing Requirements (pass/fail)	Pass
Resistance to ignition - requirements (pass/fail)	Pass
Requirements and test methods for static, impact and fatigue strengths (RESNA WC-1 Sec. 8) met?	Yes
Requirements for Resistance to ignition in accordance with RESNA WC-1 Section 16 met?	Yes

Chair Set Up & Adjustment

Contents in the Box

List of items included in the box:

- Mobility base and seating module
- Set (pair) of rear wheels
- User's Guide
- Accessories as ordered
- 5/32" Allen wrench

How to Remove Chair from Box

1. Place box flat on the floor.
2. Verify that package is in good shape and that no damage has occurred during shipping.
3. Remove the chair from the packaging material.
4. Check to make sure that your order is complete.

Preparing the Chair for Use

Once you have all components as ordered, the directions in this User's Guide will guide you through the process of preparing the chair for use.

Convoid recommends the initial fitting, adjustments, and setup take place with the help of your Convoid Representative and/or Convoid Service Dealer. However, if the instructions contained in this user's guide are followed carefully, a caregiver or attendant will be able to set up and assemble the chair.

Tools Required

- 5/32" Allen wrench (included)
- 7/16" Wrench
- 3/8" Wrench
- Phillips Screwdriver

Unfolding the Chair

Unfolding Instructions with Seating Module Attached to Mobility Base:

1. Install rear wheels on mobility base if they have been removed. Confirm the wheels are all the way in and that you have heard the “click”, indicating securement on the axle.
2. Pull on the recline cord on the back of the seating module, and bring the seat back to an upright position. **Fig. 18**
3. Install 90° removable front riggings by squeezing red levers on both right and left sides and slide onto leg rest extension tube. **Fig. 19**

Preparing Mobility Base without Seating Module:

1. Install rear wheels if they have been removed. Confirm that the wheels are all the way in and that you have heard the “click” indicating securement on the axle.



WARNING: Keep fingers free of folding mechanism.

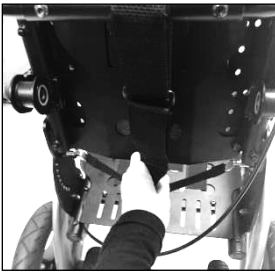

Fig. 18

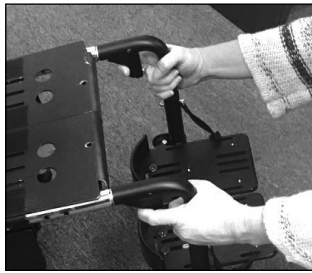





Fig. 19

Folding/Unfolding the Seating Module

The Flyer Chair can be folded into a compact mode that is ideal for transport and storage. Folding action may be limited with positioning equipment installed. Always properly secure the Flyer in a safe location when transporting as cargo in a vehicle.

 **WARNING:** Never attempt to fold the Flyer Chair with a user in it. This could result in serious injury.

 **WARNING:** Do not place user in the chair until you have verified that the folding action is properly locked.

 **WARNING:** When loaded into a vehicle always be sure that the seating module and mobility base are properly secured.

 **WARNING:** Do not allow children near the chair while folding to avoid possible pinch points.

 **WARNING:** Make sure tilt is returned to upright position before folding.

Folding Instructions with Seating Module Attached to Mobility Base:

1. Remove user from the chair.
2. While holding the back on the push handle, pull on the recline cord. Make sure you are pulling from the center of the pull strap. **Fig. 20**
3. Fold the seat back forward by pulling on the recline cord and pushing the seat back forward, then release recline cord. **Fig. 21**
4. Simultaneously grasp and squeeze red levers on both sides of the 90 degree removable leg rest (if equipped) and pull out to remove. Folding may be limited by positioning components. **Fig. 22**

Unfolding Instructions with Seating Module Attached to Mobility Base:

1. Move the seat back to the upright position.
2. Adjust seat to back angle to desired position and release the recline cord.

NOTE: Check for proper pin engagement.



Fig. 20

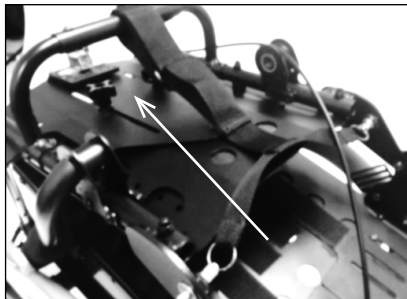

Fig. 21



Fig. 22

Lifting/Carrying the Seating Module

1. To safely lift or carry the Seating Module, hold it using two hands. **Fig. 23**
2. With one hand, hold the seating module by the backrest handle bar located on the back of the seating module. **Fig. 24**
3. With the other hand, hold the lock bar located on the bottom of the seat. **Fig. 25**



Fig. 23

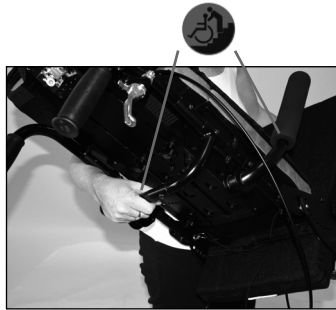

Fig. 24

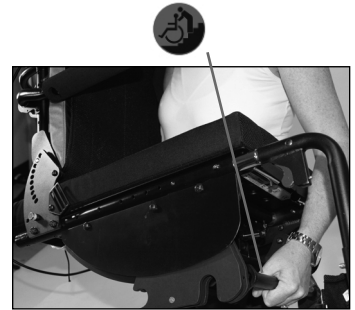

Fig. 25

Lifting/Carrying the Mobility Base

1. To safely lift or carry the Flyer, grasp the curved side mobility base tubes using two hands, keeping clear of wheels and accessories. **Fig. 26**

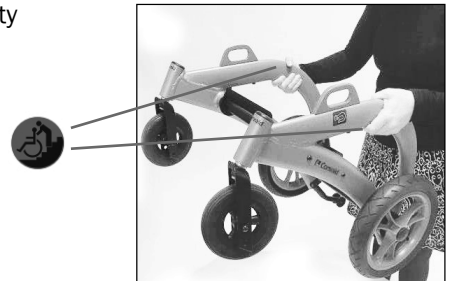





Fig. 26

-  **WARNING:** ALWAYS carry the seating module by the seating module backrest handle bar and the seating module's lock bar.
-  **WARNING:** ALWAYS check that the seating module tilt and recline mechanisms are locked in place before attempting to lift or carry the seating module.
-  **WARNING:** When carrying/lifting the Flyer, please keep your hands away from folding mechanisms.
-  **WARNING:** Accessories will add extra weight to the module. Lift with caution.

Installing Seating Module onto Mobility Base

1. Ensure wheel lock is engaged.
2. Adjust seat back angle to upright 90 degrees position by pulling on the recline cord and adjusting the seat upright. **Fig. 27**
3. Carefully lift the seating module using both hands, with one hand holding the seating module's upper back, and with the other hand holding the seating module's lock bar, located on the bottom of the seat. **Fig. 28**
4. Face the seating module forward at a 45 degree angle over the mobility base docking tubes, in between alignment plates on frame. Align rear docking plate insert on seating module with rear cross tube on mobility base. **Fig. 29**
5. With seating module resting on rear mobility base tube, slide safety latch lock lever and lift docking latch tube. **Fig. 30**
6. Pivot forward. Once fully docked, seating module will automatically click in place. Ensure that docking latch is firmly attached. **Fig. 31**



Fig. 27



Fig. 28

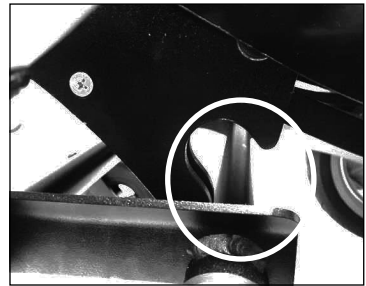

Fig. 29

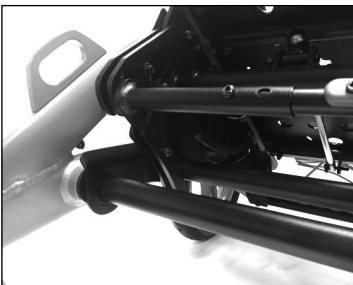

Fig. 30

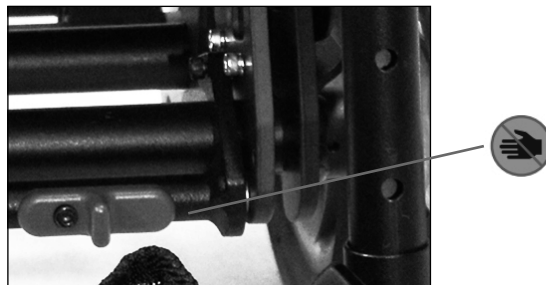



Fig. 31

 **WARNING:** Check proper seat module docking before placing user in chair. Check docking by lifting front seat pan up and down to ensure seating module does not disengage from mobility base.

 **WARNING:** Before placing user in the chair, make sure wheel locks are engaged.

Removing Seating Module from Mobility Base

1. Engage wheel locks.
2. Remove user from the chair.
3. Adjust the seat back to upright position.
4. Adjust tilt to neutral position so that the seat pan is parallel to the floor.
5. Hold seat base lock bar and push safety lock release lever
6. Lift seat module safety latch lock. **Fig. 32**
7. Once the seating module safety latch lock is released, push on the upper back to release seating module from docking tubes on the mobility base.
8. Lift seating module from the mobility base.

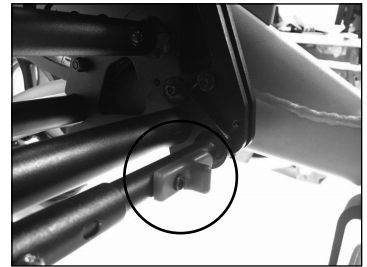



Fig. 32

 **WARNING:** Always remove the user from the chair prior to removal of the seating module from the mobility base. Removal of the seating module is only intended for facilitating lifting and transportation of the chair. The user should never be placed in the seating module if it is not properly attached to the mobility base. The mobility base should never be used without the seating module assembly properly installed.

 **WARNING:** The seating module shall NEVER be used as a car seat.

Fitting Guide

Please take the time to properly adjust the chair to fit the user. If the user is not correctly positioned, check the accessories listed in this User's Guide to see if one or more of our accessories would help to facilitate posture, or consult a healthcare professional. When properly fitted, Convaid chairs will provide years of comfortable use. As the user grows, refer back to this Fitting Guide to adjust the dimensions of the chair. Convaid recommends the initial fitting, adjustments, and set-up takes place with the help of your Convaid Representative and/or Convaid Service Dealer.

Seat Back Height



The back height varies according to chair size. A head support is available when extra height is needed to support the head. To determine the back height, measure from the seat to the upper portion of shoulder. **Fig. 33**

Fig. 33

Back Height Adjustment

1. Loosen the two back plate adjustment knobs. **Fig. 34**
2. Loosen the chair upholstery attached to the back as necessary.
3. Slide the back up or down carefully to desired position. **Fig. 35**
4. Tighten knobs and check for proper position of all items loosened in step 1.



WARNING: Confirm that all adjustment knobs and accessories are properly tightened on the seating module before placing user back in the chair or using the chair.

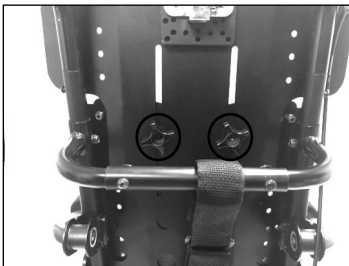

Fig. 34

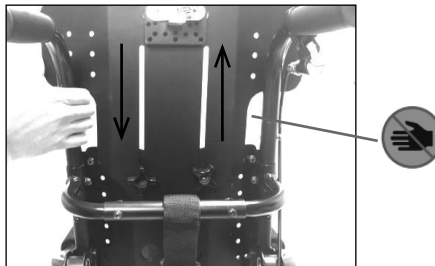

Fig. 35

Seat Depth Adjustment

Measure from the most posterior portion of the buttocks to the back of the knee. Subtract from that measurement 1-2" (25-51mm) to allow adequate clearance between the seat and the back of the knee.

1. Remove the user from the chair.
2. Remove seating module from base and remove the cushions.
3. Set the seat back recline to 90 degrees (2nd hole from the top). **Fig. 36 & 37**
4. Follow the Cane Position seat depth adjustment chart for the seat depth position range. **Fig. 37**

Make note of all spacers and washers location and sequence for proper reinstallation.

5. Loosen any accessories that may prevent the seat pan from sliding.
6. Using a 5/32" Allen wrench for bolts, and 7/16" wrench for nuts, remove 2 horizontal bolts and nuts from both sides of seating module. **Fig. 38**
7. Remove 2 bolts and nuts from the back of the seating pan. **Fig. 39**
Loosen two (2) adjustment bolts located within the adjustment slots on the top of the seat pan. Do not remove nuts from bolts. **Fig. 40**
8. Adjust seat tubes with pan attached to desired depth by aligning holes on the stationary seat base with the incremental holes on the seat tubes. Reattach the hardware previously removed hardware in step 7. Retighten any loosened hardware.
9. Push seat pan back evenly on both sides, until the seat reaches the desired depth.
10. Tighten the adjustment knobs and any loosened accessories.



WARNING: Back cane position is set at a factory setting. Warranty will be voided if settings are modified or adjusted outside of factory.

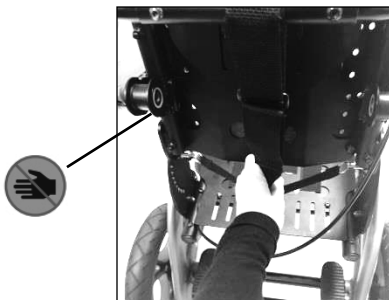

Fig. 36



Fig. 37

Factory Set Positions

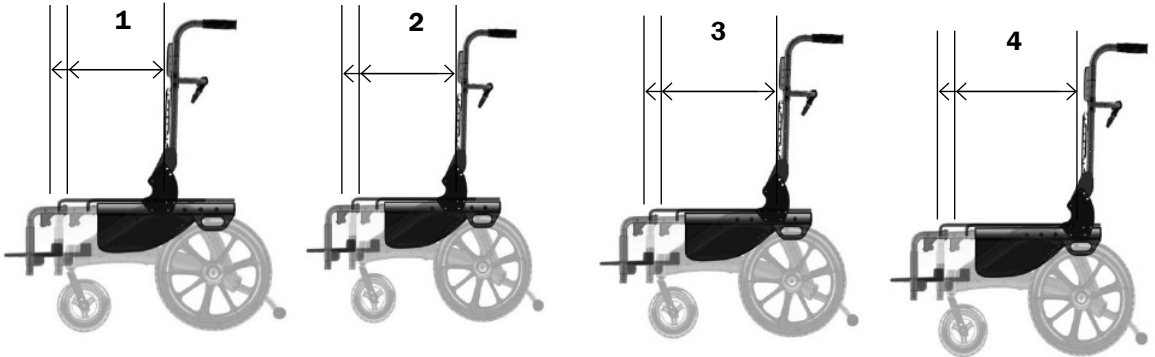

Fig. 38

Cane Position	1	2	3	4
Seat Depth Adjustment Range	11-15"/ 279-381 mm	13-17"/ 330-432 mm	15-19"/ 381-483 mm	17-21"/ 432-533 mm



Fig. 39

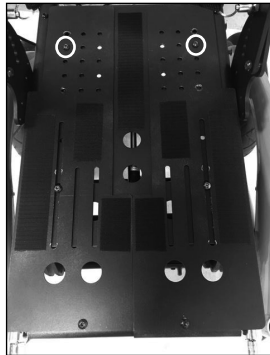

Fig. 40

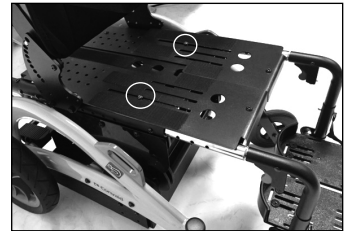

Fig. 41



WARNING: When the back cane is factory set to position 1 the total weight carried by the Flyer must never exceed 85 lbs./39 kgs.



WARNING: Do not place user on the chair while seat adjustment hardware is loosened. Make sure the hardware is fully tightened before placing the user on the chair.

Note: Weight capacity depends upon position of back canes as indicated in **Fig. 38 and 43**. Please refer to the Serial Number Label in **Fig. 43**.

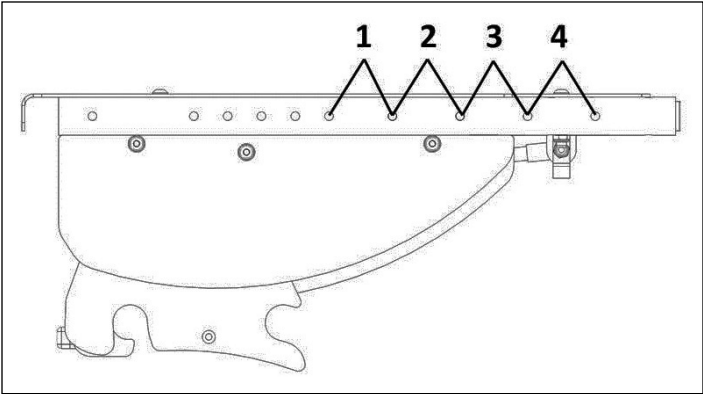

Fig. 42

















 2017-7	<p>FLYER (Module) S/N: FL-P1T-00001</p>	 MAX 85 lbs				
 2017-7	<p>FLYER (Module) S/N: FL-P1-00001</p>	 MAX 85 lbs				
 2017-7	<p>FLYER (Module) S/N: FL-P3T-00001</p>	 MAX 170 lbs				
 2017-7	<p>FLYER (Module) S/N: FL-P3-00001</p>	 MAX 170 lbs				

Fig. 43

Seat Width Adjustment

Note: Seat width ranges from 12" - 16" (305-406 mm).

Follow **Fig. 44** and adjustment chart (**Fig. 45**) to adjust the seating module to desired width.

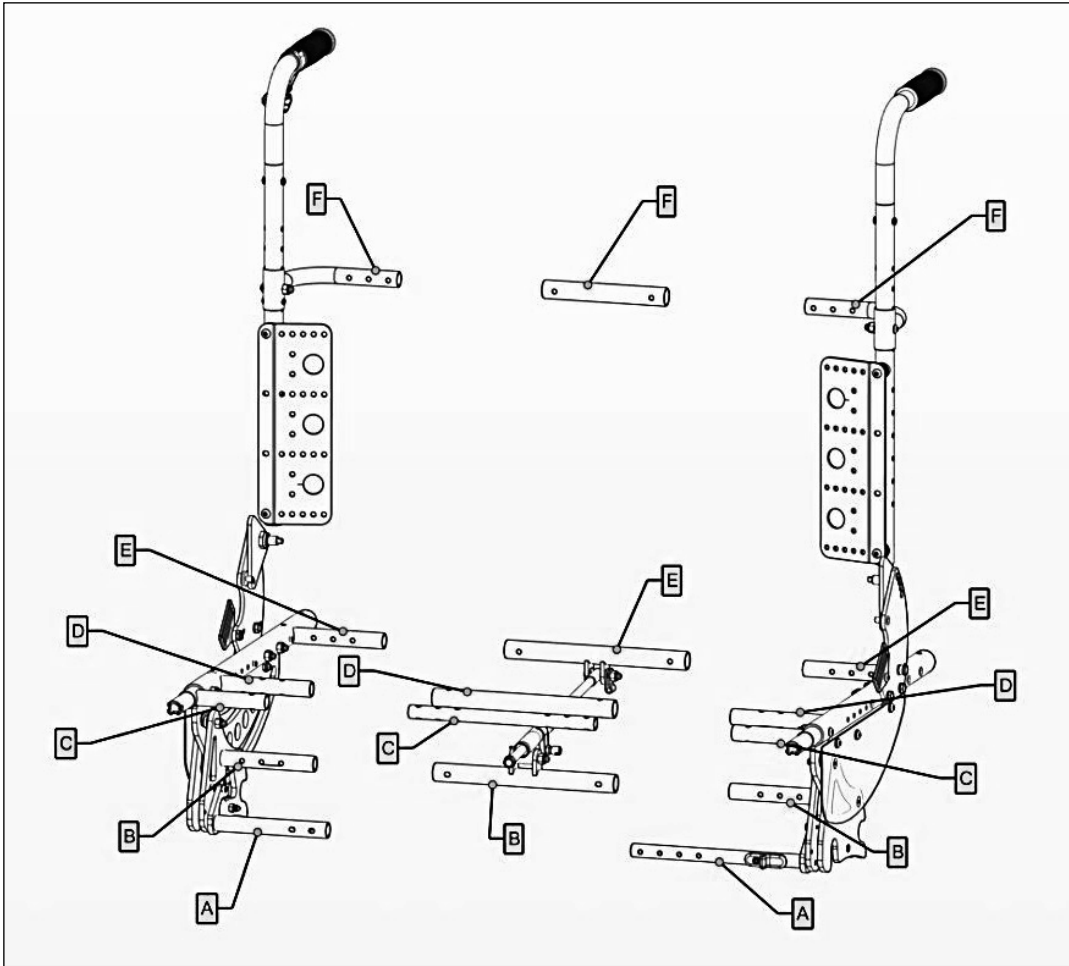

Fig. 44 Telescoping Tubes Location

Size	12"	13"	14"	15"	16"
Tube A	L4	L3	L2	L1	R1
Tube B	L1 & R6	L2 & R6	L3 & R6	L3 & R5	L3 & R4
Tube C	L3 & R4	L2 & R4	L1 & R4	L1 & R5	L1 & R6
Tube D	L1 & R6	L2 & R6	L3 & R6	L3 & R5	L3 & R4
Tube E	L1 & R6	L2 & R6	L3 & R6	L3 & R5	L3 & R4
Tube F	L1 & R6	L2 & R6	L3 & R6	L3 & R5	L3 & R4

Fig. 45 Adjustment Chart

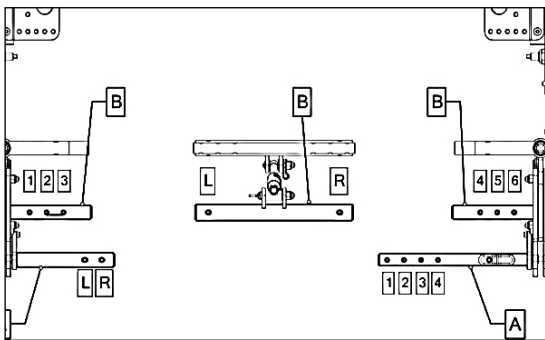

Fig. 46 Front View (Tube A & B)

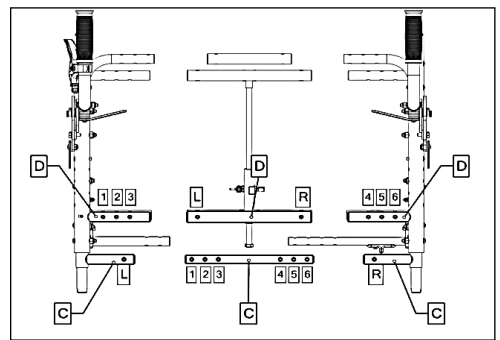

Fig. 47 Top View (Tube C & D)

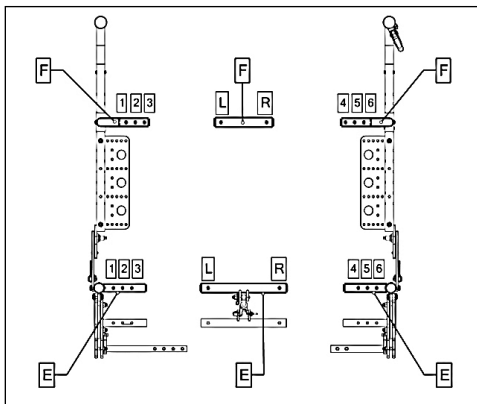

Fig. 48 Back View (Tube E & F)

To Remove the Width Adjustment Bolts

Use 5/32" Allen wrench and 7/16" wrench to remove any adjustment bolts.

1. Remove seating module from mobility base following instructions on page 29.
2. Remove any cushions or upholstery attached to seating module.
3. Remove the removable leg rest. **Fig. 49**
4. On the top of the seat pan, remove the six adjustment bolts located on top of the seat pan. **Fig. 50**
5. On the front of the chair, remove the three adjustment bolts on the docking latch assembly. **Fig. 51**
6. On the seat back pan, remove the four adjustment bolts connecting the side pans with the center pans. **Fig. 52**
7. On the back of the chair, remove the adjustment bolts on the back cross tube and lower cross tube. **Fig. 53**

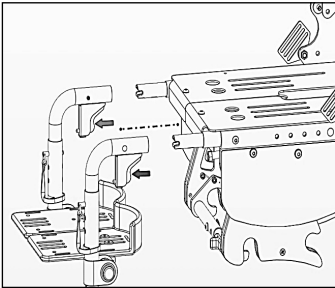

Fig. 49

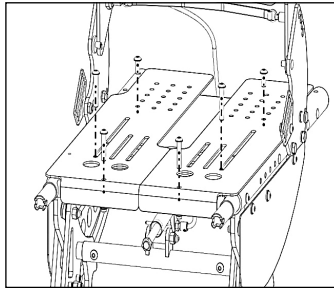

Fig. 50

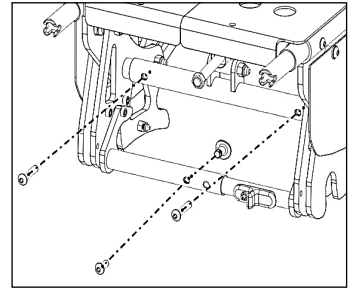

Fig. 51

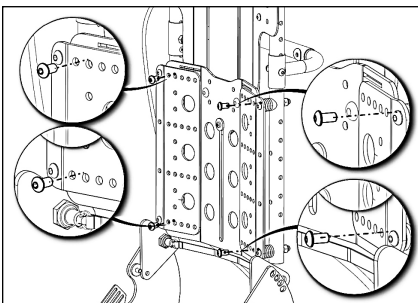

Fig. 52

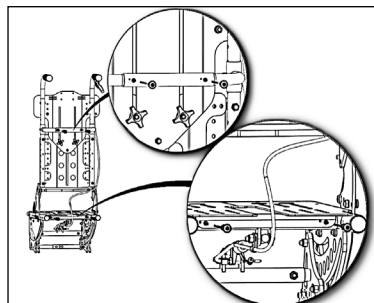

Fig. 53

Note: If one piece push handle is installed, additional growth kit must be purchased.

Mobility Base Width

The Flyer mobility base is designed to accommodate growth by using the Growth Kit components.

Mobility Base Width Adjustment

1. Remove 2 bolts and 2 washers from each side of Cross Tubes "A" and "B".
2. Set aside 2 guide plates.
3. Remove axle pins from both sides of mobility base.
4. Remove 2 bolts from each brake tube.
5. Remove 2 screws from each side of brake pedal.
6. Install new cross and brake tubes from growth kit in order depicted below, with "A" in front, followed by "B", and "C" and "D" in the far rear.
7. Re-install all previously removed hardware, guide plates and axle pins.

Note: Growth Kit will include instructions.

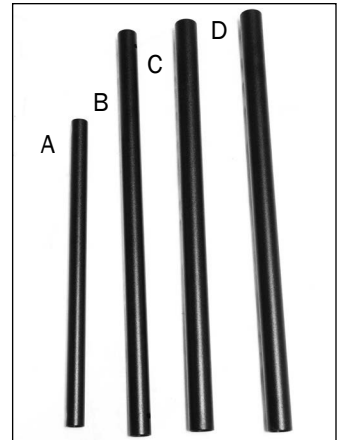

Fig. 54

Tilt-In-Space Adjustment

The Flyer is equipped with a tilt-in-space mechanism. The tilt-in-space range in the Flyer is -5° anterior to 40° posterior.

To Adjust the Tilt Angle:

1. With your left hand, hold onto the back cross tube, on the back of the seat to support the weight of the user. **Fig. 55**
2. With your right hand, squeeze the tilt lever on the handle. **Fig. 56**
3. Move the user to the desired tilt angle while holding the handle and the tilt lever.
4. Release the lever to engage the tilt lock.

Note: The tilt has a stopper so the tilt is locked when the lever is released.

Note: When releasing the tilt handle, verify the mechlock is engaged.



Fig. 55



Fig. 56



WARNING: When activating the tilt, gradually squeeze the lever to allow the care giver to support the weight.



WARNING: In preparation to operate the tilt:

- Always verify that the arms of the user are stable and within the seat base.
- Always verify that the user's legs are stable and on the foot support.
- Never place hands, feet or foreign objects into the tilt mechanism area.
- Never add chair accessories that are not specifically designed for the Flyer Chair, as they may interfere with the tilt mechanism.
- Never allow the user's head to tilt/recline beyond the horizontal plane to the floor.
- Never operate the tilt mechanism without having a firm hold of the push handle.
- When tilting the chair, be aware that a change in angle can create a sudden weight shift.

Cross Tube Adjustment on Back Canes

The cross tube, on the seating module equipped with back canes, can be adjusted vertically to accommodate the placement of aftermarket seating hardware.

1. Remove the bolts and nuts with a 5/32" Allen wrench and 7/16" wrench.
2. Slide the back cane cross tube up or down carefully to the desired position. **Fig. 57**
3. Reinstall the hardware.



Fig. 57



WARNING: If tilt handle is attached to back cane cross tube, extra cable slack may be experienced when back cane cross tube is adjusted to the lower position. Tiedown the cable to manage the excess cable slack. Do not bend or crimp the tilt cable as it will hinder docking and tilt operations.

Recline Adjustment

The Flyer comes standard with back angle adjustment of 80° - 110° in increments of 10°. **Fig. 58**

Optional Feature:

1. The Flyer has an additional recline option to extend the back angle adjustment to full recline range of 80° to 170° of recline adjustment. **Fig. 59**
2. Make sure wheel locks are engaged.
3. If user is in the chair, move the user's back forward slowly and carefully to shift user's weight.
4. Grab the pull strap on the center of the recline cord. **Fig. 60**
5. With your free hand on the top of the back, and while holding the recline cord, adjust the back to the desired recline angle and release the pull strap.
6. Confirm that the recline lock pins are fully engaged on both sides. **Fig. 61**
7. Replace user to relaxed position. Release wheel locks.

Recline Degrees
(Standard)
80° - 110°

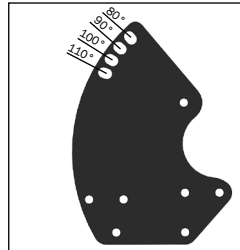

Fig. 58

Recline Degrees
(Option)
80° - 170°

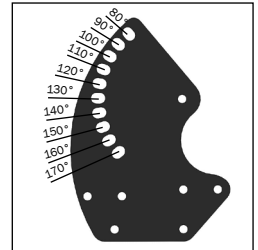

Fig. 59



Fig. 60



Fig. 61



WARNING: Engage the wheel locks prior to adjusting recline angle.



WARNING: Check to confirm that recline lock pins are fully engaged prior to use. This indicates that the recline position is locked.



WARNING: Keep fingers free of recline mechanism.



WARNING: Never allow the user's head to tilt/recline beyond the horizontal plane to the floor.

Note: Recline Angle can also be referred to as seat-to-back angle or back angle adjustment.

Positioning Belts



WARNING: Positioning belts should never be used as a safety restraint device in a motor vehicle when transporting chair with occupant. An additional WC-4-19 compliant automotive type seat belt is required when the chair is used in transport vehicles.



WARNING: Positioning belts and harnesses should only be installed by a Convaid provider or healthcare practitioner.

Pelvic Positioning Belts

Make sure the occupant does not slide down in the wheelchair seat.

1. Feet must be planted on footplate and securely anchored to prevent sliding forward off seat, in conjunction with using appropriate pelvic positioning belt. Position client as directed by healthcare practitioner. The belts must be snug, but not too tight. You should be able to slide your open hand, flat between the belt and the occupant.
2. NEVER use positioning belts as a user restraint, or on an occupant who is comatose or agitated.

Note: Failure to heed above warnings may cause serious injury.

Two-Point Positioning Belt

To Buckle:

Snap together the two straps at the buckle. **Fig. 62**

To Release:

Press on each side to release buckle and pull away from each other.



Fig. 62

Back Pan Cam Locks Positioning

To Operate:

1. Position Camlock to "open" position **Fig. 63**
2. Feed webbing of vest or belt into hinged end of Camlock as shown. **Fig. 63**
3. Once adjusted to desired length firmly close Camlock to "closed" position. **Fig. 64.**
4. Ensure webbing is secure by pulling fixed end of webbing to simulate usage. Ensure webbing does not slip.
5. To release webbing, position Camlock to "open" position and pull webbing completely out of Camlock.



Fig. 63

To Reposition:

Back Pans: Camlocks will come preinstalled. To reposition, follow the steps below.

1. Position Camlock to "open" and remove any webbing **Fig. 63**
2. Using a Phillips Head screwdriver and a Flat Head screwdriver on each side of the binding post; remove binding post by simultaneously rotating each side counterclockwise until removed from pans.
3. Reinstall hardware into desired position using any accessible hole on back pans by following the hardware orientation shown in **Fig. 65 and 66**
4. Repeat as desired for other installed Camlocks.

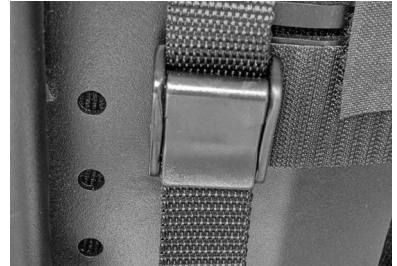

Fig. 64

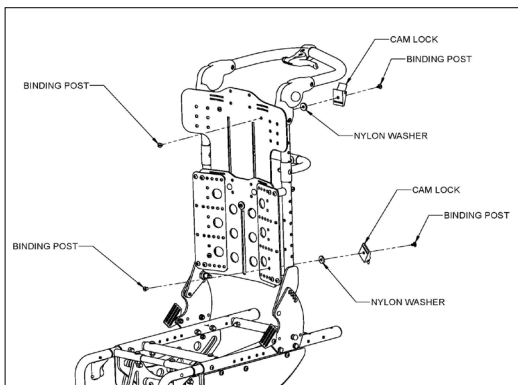

Fig. 65

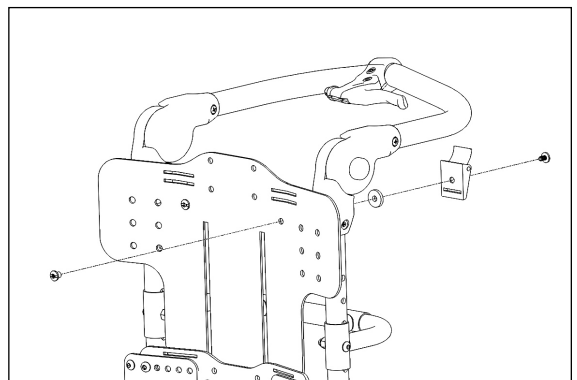

Fig. 66

Seat Pan Belt:

Camlocks and Belt Brackets will come preinstalled. To reposition, follow the steps below.

1. Position Camlock to “open” and remove any webbing.
2. Using a Phillips Head screwdriver and a Flat Head screwdriver on each side of the binding post; remove binding post by simultaneously rotating each side counterclockwise until removed from recline plate.
3. Reinstall hardware into desired position on recline plate by following the hardware orientation shown in **Figures 67 and 68**.
4. To reposition Belt Bracket, use a 5/32” Allen wrench and a 7/16” wrench to remove the bolt and nut from the seat tube.
5. Reinstall hardware into desired position using any accessible hole on seat tube by following the hardware orientation shown in **Figures 67 and 69**. Repeat as desired for other installed Camlocks or Belt Bracket

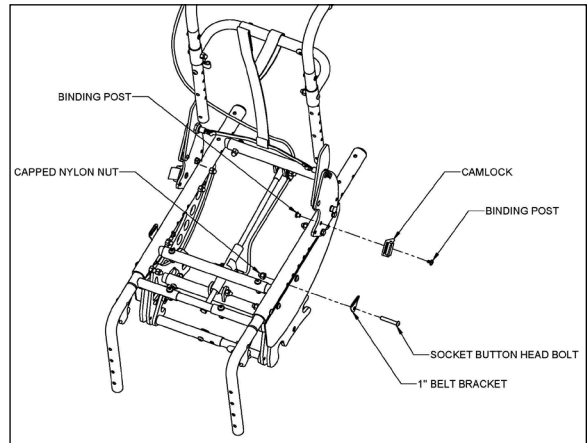

Fig. 67

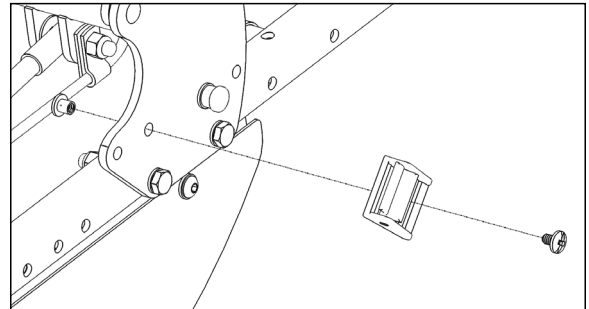

Fig. 68

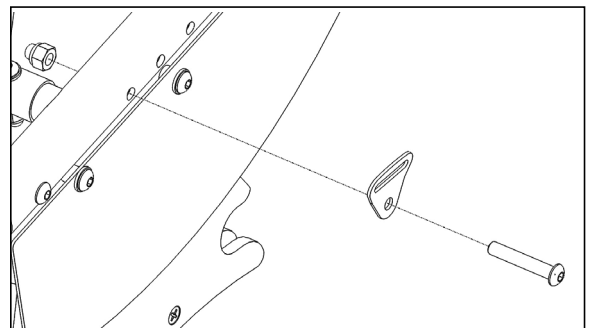

Fig. 69

Footplate Adjustment

Flyer foot support is height adjustable. To determine the correct seat-to foot support height, measure from the back of the knee to the bottom of the heel. The soles of the feet or heels should rest comfortably on top of the footplates. **Fig. 70**

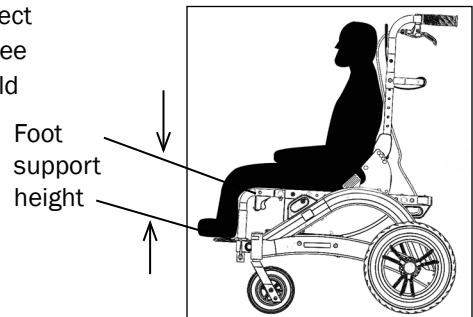

Fig. 70

To Adjust the Height on Fixed Individual Footplates (standard) and Angle-adjustable Individual Footplates (Option):

1. Remove detent pins, circled in **Fig. 71 & 72**.
2. Slide footplate up leg rest extension tube until desired height has been reached. **Fig. 73**
3. Reinsert detent pins.
4. Repeat on opposite side.



Fig. 71



Fig. 72



Fig. 73

Note: Caster interference may occur when seat is in upright position. Seat must be tilted back at least 5° or legrests must be elevated to allow caster swivel.

To Adjust the Height on One-Piece Footplate:

1. Remove detent pins from both sides of footplate, circled in **Fig. 74**
2. Slide footplate up leg rest extension tube until desired height has been reached.
3. Reinsert detent pins on both sides.



Fig. 74

Foot Positioners

Adjustable foot positioners hold feet in position on the footplate. The foot positioners may be criss-crossed over the top of the foot to secure the entire foot. **Fig. 75**

The foot positioners can also be converted to an ankle strap. To convert into an ankle strap, remove left buckle and secure the loose end of the strap. Wrap the right strap around the ankle and fasten the buckle. **Fig. 76-80**

To attach the positioners, thread the strap through top of foot support, and bolt to underside of foot support, using a Phillips screwdriver. **Fig. 76**



Fig. 75



Fig. 76



Fig. 77



Fig. 78



Fig. 79



Fig. 80

Wheels

Wheels Specifications

The Flyer has 2 wheel options available, depending on your seat-to-floor requirements:

- 6" x 2", 11.5" x 2.5" (optional) 152 x 51 mm, 292 x 64 mm (optional)
- 7.5" x 2", 16" x 2" (optional) 191 x 51 mm, 406 x 51 mm (optional)

You can upgrade, replace or reorder Flyer tires at any time. You have the option of reordering replacement standard solid tires. When ordering upgraded or replacement tires, please have the following information available:

- Chair model and size (ex: FL12)
- Wheel size (ex: 7.5" x 2"/191mm x 51mm)

Wheel Lock Operation

To Lock Wheels:

Push the wheel lock bar downwards and roll the wheelchair slightly back or forward so that the lock pins can engage into the hub lock disk. **Fig. 81**



Fig. 81

To Unlock Wheels:

To disengage the wheel lock, pull the wheel lock bar upwards with your toe.

Fig. 82



Fig. 82



WARNING: Do not use excessive force or stand on wheel lock bar.

Removal & Installation of Rear Wheels

To Remove the Wheels:

1. Release the wheel locks (wheel lock bar “up”).
2. Press down on the clip near the center of the wheel hub. **Fig. 83**
3. Pull the wheel outward to remove it from the chair. **Fig. 84**



WARNING: Do not remove silver clip.



Fig. 83



Fig. 84



Fig. 85

To install the wheels:

1. Make sure the wheel lock lever is released (wheel lock bar “up”).
2. Hold the axle and wheel. Align the wheel hub with the axle.
3. Slide the wheel as far as possible onto the axle until you hear a “click”. **Fig. 85**
4. Ensure the wheel has secured on the axle by pulling outward on the wheel without pressing clip.
5. Wheel will not come off if clip is properly engaged.

Accessories

Head Support

Attaching Head Support:

1. Remove head support cover by unzipping the cover on the back side. **Fig. 86**
2. Using a 5/32" Allen wrench and 7/16" wrench, secure the two provided mounting Allen screws on the top center of the upper back plate. **Fig. 87**
3. Adequately tighten hardware.

Adjusting the Head Support:

1. Remove head support cover by unzipping the cover. **Fig. 86**
2. Using a 5/32" Allen wrench and 7/16" wrench, loosen the two provided mounting Allen screws. **Fig. 87**
3. To adjust the height, once the mounting hardware has been loosened, move the head support up or down as needed. **Fig. 88**
4. Secure the mounting hardware adequately and replace cover.



Fig. 86

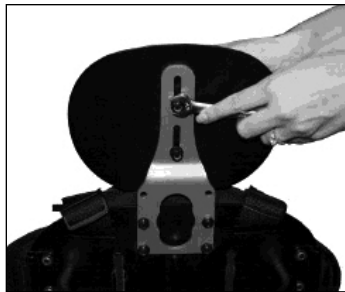

Fig. 87



Fig. 88

Adjustable Headwing Headrest Instructions

1. Unzip the cover from the back of the headrest.
2. Slightly move the cover to reveal the silver locking screw on the plastic headrest plate.
3. Note that the locking screw of the right hand side is on the top portion of the pivot hinge.
4. The locking screw of the left hand side is on the bottom portion of the pivot hinge.
5. Using a 5/32" Allen wrench to loosen the screw.
6. Rotate the adjustable wings of the headrest to the desired location. **Fig. 89**
7. Use a 5/32" Allen wrench to tighten screw.
8. Repeat steps 4 to 7 for the other side.



Fig. 89

Universal Headrest Bracket Installation Instruction

1. Insert screw into one of the four holes on the upper portion of the back pan. **Fig. 90**
2. Orient the universal plate to desired position. **Fig. 91 & 92**
3. Partially thread the screw onto the plate but do not tighten. **Fig. 93**
4. Repeat steps 1 to 3 for the other three attachment screws.
5. Using a 5/32" Allen wrench, tighten all four attachment screws.

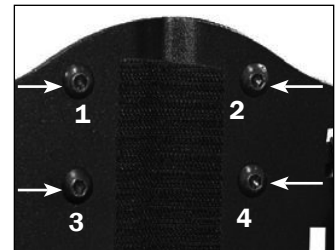

Fig. 90

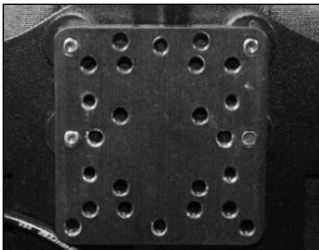

Fig. 91

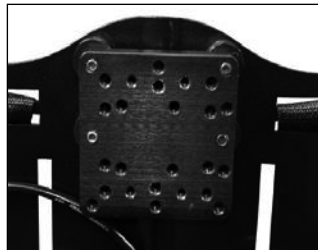

Fig. 92



Fig. 93

Anatomic Headrest Installation

Installing Anatomic Headrest to Turtle Bar System:

1. Align the anatomic headrest bracket with turtle bar system.
Fig. 94
2. Use 6mm Allen wrench to tighten the connecting hardware.
Fig. 95

Note: Do not remove the preinstalled head rest bracket. **Fig. 94**

Note: Universal bracket must be oriented to the position as shown in **Fig. 96**

Installing the Headrest Mount onto the Universal Bracket:

1. Locate the center securement hole located on the universal bracket. **Fig. 96**
2. Use 4mm Allen wrench to tighten the connecting hardware. **Fig. 97**
3. Install the anatomic headrest turtle bar system into the bracket shown in **Fig. 98**
4. Adjust to desired height and secure the system by tightening the securement bolt with 5mm Allen wrench.

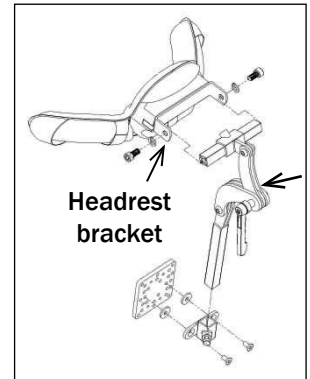

Fig. 94

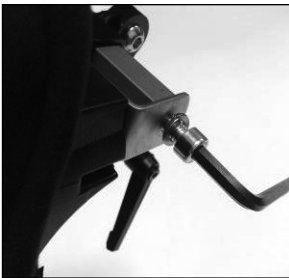

Fig. 95

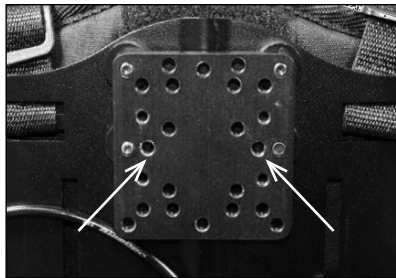

Fig. 96

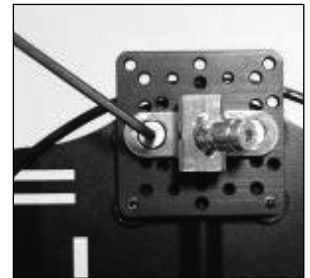

Fig. 97

Installing the Headrest Mount onto the Universal Bracket:

1. Locate the center securement hole located on the universal bracket. **Fig. 96**
2. Use 4mm Allen wrench to tighten the connecting hardware. **Fig. 97**
3. Install the anatomic headrest turtle bar system into the bracket shown in **Fig. 98**
4. Adjust to desired height and secure the system by tightening the securement bolt with 5mm Allen wrench.



Fig. 98



WARNING: Do not set height beyond the maximum indicated line.

To Adjust the Turtle Bar System

1. Use 5mm Allen wrench to loosen the bolts and loosen the lever. **Fig. 99**
2. Adjust to desired depth and height then retighten the bolts and lever.

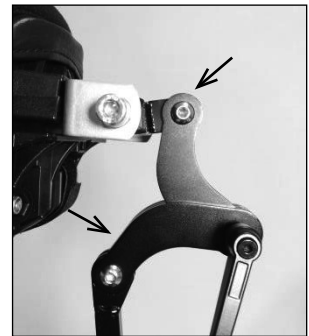

Fig. 99

To Remove Cover

Detach the three Velcro® strips and remove cover. **Fig. 100**

To Install Cover

Slide cover onto the headrest unit and secure with Velcro® strips. **Fig. 101**



Fig. 100



Fig. 101

Adjustable Headrest Installation

Installing the Adjustable Headrest to Turtle Bar System:

1. Align the adjustable headrest bracket with the turtle bar system.
2. Use 6 mm Allen wrench to tighten the connecting hardware.

Note: Do not remove the preinstalled headrest bracket.

Note: Universal bracket must be oriented to the position shown in **Fig. 102**.

Installing the Headrest Mount onto the Universal Bracket:

1. Locate the center securement hole located on the universal bracket.
2. Use 4 mm Allen wrench to tighten the connecting hardware.
3. Install the Adjustable Headrest Turtle Bar Assembly into the bracket, as shown in **Fig. 103**
4. Adjust to desired height and secure the system by tightening the securement bolt with 5 mm Allen wrench. **Fig. 104**.

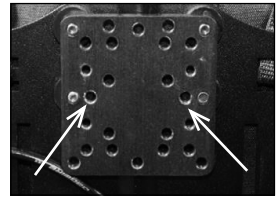

Fig. 102



Fig. 103



Fig. 104

To Adjust the Turtle Bar System

1. Use 5mm Allen wrench to loosen the bolts and loosen the lever. **Fig. 105**
2. Adjust to desired depth and height then retighten the bolts and lever.



WARNING: Do not set height beyond the maximum indicated line.



Fig. 105

Upper Extremity Support Surface (Tray)

The trays are ideal for feeding and for trunk stabilization. They feature a safety lip and are easy to clean.

1. Depress spring button on underside of armrest until tray mount tube pops out.
2. Grasp tray mount and extend until locked into position. **Fig. 106 & 107**
3. While holding the tray with both hands, squeeze black handles and slide onto ends of tray mount. **Fig. 108**
4. When returning tray mount tube inside, maintain alignment of indent button in order to secure indent button into correct hole.



WARNING: The Upper Extremity Support Surface (Tray) with Flip-Up armrests are not recommended to be used in transportation.



Fig. 106



Fig. 107



Fig. 108

Height Adjustable Removable Armrests and Tray

Installation/Removal:

1. Align armrest post with receiver on seating module in the orientation shown. **Fig. 109**
2. Fully insert armrest downwards into receiver until the armrest stop rests on the seating module receiver.
3. To remove, press and hold gray receiver button while simultaneously pulling the armrest upwards and out of the receiver. **Fig. 110**



Fig. 109



Fig. 110

Adjusting the height:

1. Using a 5mm Allen wrench, remove the height adjustment bolt and stop from the armrest post.
Fig. 111
2. Reinstall bolt and stop in the same orientation to the desired height using the adjustment holes along the armrest post.

Adjusting the weight:

1. Using a 5mm Allen wrench, loosen the two vertical facing bolts (1 front and 1 rear) underneath the armrest pad. **Fig. 111**
2. Slide armrest pad to desired width and retighten bolts.

Adjusting the Angle:

1. Loosen hand knob on side of armrest, by rotating knob counter-clockwise. **Fig. 111**
2. Adjust armrest pad to desired angle and retighten knob, by rotating knob clockwise.

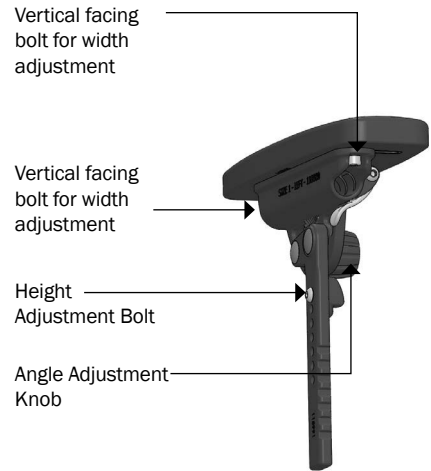

Fig. 111

Upper Extremity Tray (for Removable Adjustable Armrest)

Installation/Removal:

1. With both armrests installed, flip the white camlock on each armrest to the “open” position. **Fig. 112**
2. Align both tray tubes with the receiver in each armrest and slide tray towards the seat back.
Fig. 112
3. When tray is at desired depth, flip the white camlock on each armrest to the “closed” position to lock the tray in place. (**Fig. 113**)
4. To remove repeat steps 1-3 in reverse order.

Adjustments:

For height adjustable upper extremity tray instructions reference “Adjusting the height” above.



Fig. 112, White Camlock in Open Position



Fig. 113, White Camlock in Closed Position

Calf Panel

1. Lay Calf Panel flat and unfasten the Velcro® straps. **Fig. 114**
2. Attach Velcro straps around Footrest Extension Tube. **Fig. 115**
3. Position Calf Panel across chair and attach Velcro Straps around opposite Footrest Extension Tube. **Fig. 116**

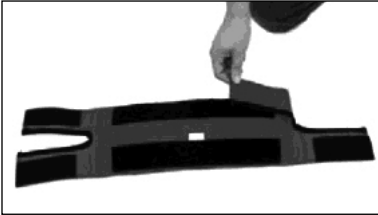

Fig. 114



Fig. 115



Fig. 116

Laterals

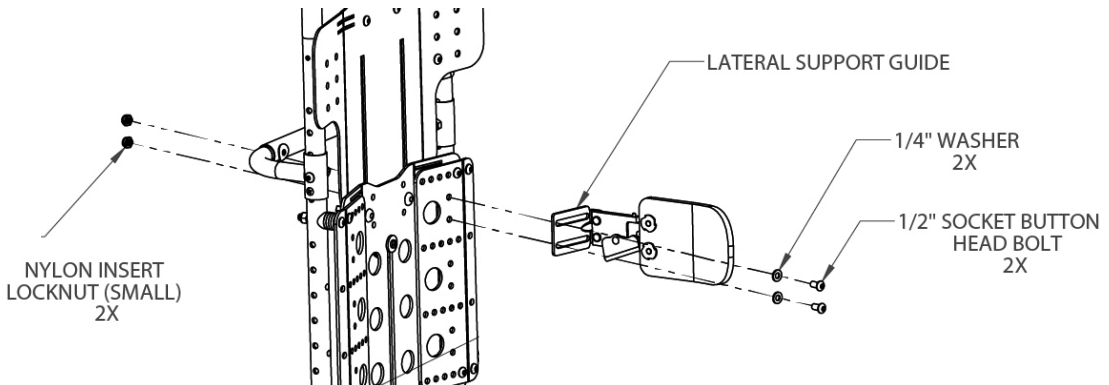

Fig. 117

To Install:

Remove cushion and attach laterals using the hardware provided using a 5/32" allen wrench and 7/16" wrench. **Fig. 117**

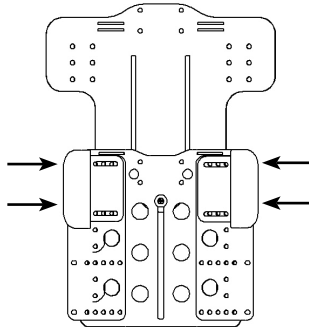

Fig. 118

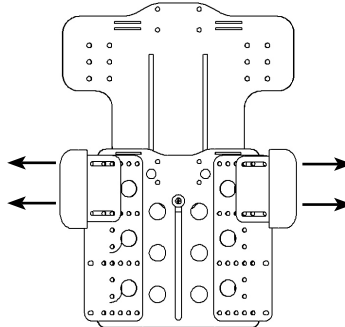

Fig. 119

Lateral Width	
Model Size	Width Range
12	8.5 - 11.5
13	9.5 - 12.5
14	10.5 - 13.5
15	11.5 - 14.5
16	12.5 - 15.5

Note: Minimum width will compact cushion.

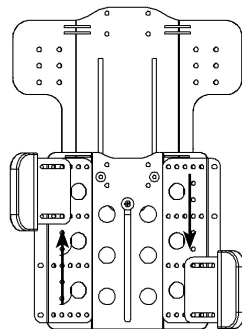

Fig. 120

Lateral Height (Fixed Laterals)	
Model Size	Height Range
12	10" - 16"
13	10" - 16"
14	10" - 16"
15	10" - 16"
16	10" - 16"

Lateral Height (Swing Away Laterals)	
Model Size	Height Range
12	8.75" - 16.75"
13	8.75" - 16.75"
14	8.75" - 16.75"
15	8.75" - 16.75"
16	8.75" - 16.75"

To Adjust:

Adjust laterals to the desired width (**Fig. 118, 119**) and height (**Fig. 120**) and secure the laterals to the solid back seat pan using the hardware provided in kit. **Fig. 121**

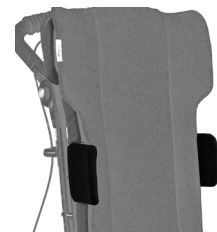

Fig. 121

Swing-Away Laterals by R82

Installation/Removal

Remove cushions from the Flyer seat and attach laterals at the desired height and width using the hardware provided and a 7/16" wrench. **Fig. 122**

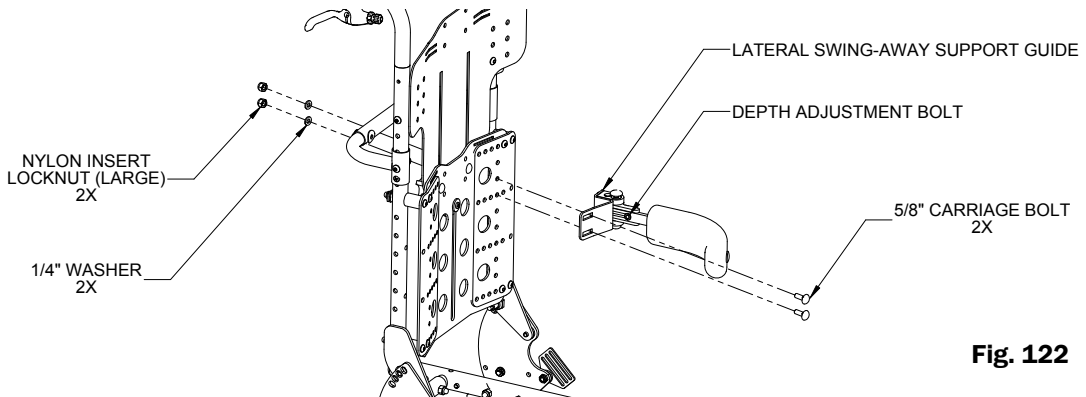

Fig. 122

Width Range for Swing-Away Laterals by R82 (in)				
Model Size	Straight Bar	Offset 1" Bar	Offset 1-3/4" Bar	Offset 2-1/2" Bar
FL 12	9.75"-10.75"	8.75-9.75	8.0-9.0	7.25-8.25
FL 13	10.75-11.75"	9.75-10.75	9.0-10.0	8.25-9.25
FL 14	11.75-12.75"	10.75-11.75	10.0-11.0	9.25-10.25
FL 15	12.75-13.75	11.75-12.75	11.0-12.0	10.25-11.25
FL 16	13.75-14.75	12.75-13.75	12.0-13.0	11.25-12.25

To adjust lateral depth

1. Loosen the depth adjustment bolt shown using a 4mm or 5/32" allen wrench. **Fig. 122**
2. Adjust to desired depth and re-tighten bolt.
3. Repeat for opposite side.

Swing Away Laterals	
Model Size	Height Range (in)*
FL 12	8-15
FL 13	8-15
FL 14	8-15
FL 15	8-15
FL 16	8-15

*To top of lateral bar
Each lateral bar has 1-1/2" of depth adjustment

Hip Guides

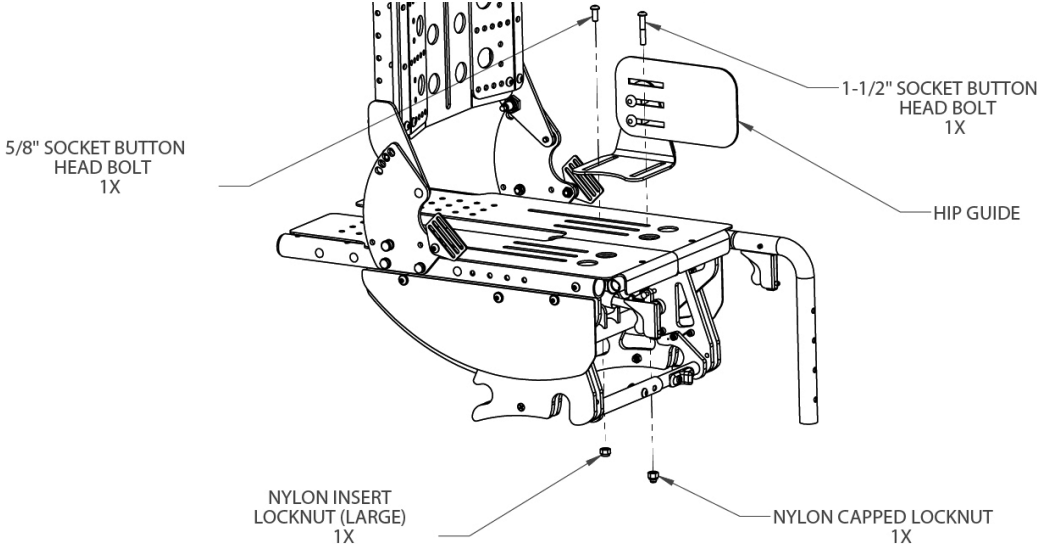
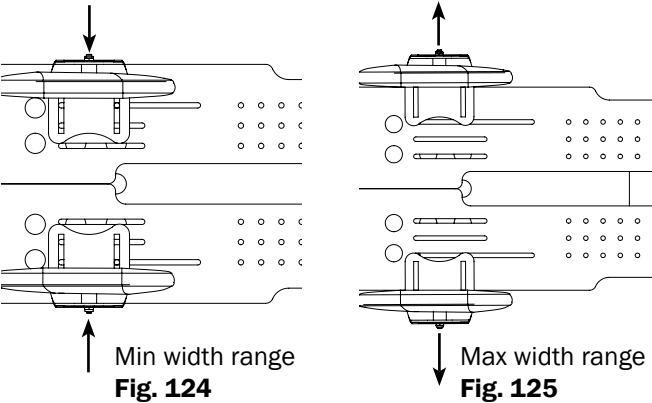

Fig. 123

To Install:

To install hip guides remove cushion and existing socket button head bolt on the top of the seat pan and by unscrewing the nylon capped locknut on the bottom of the seat pan by using a 5/32" allen wrench and 7/16" wrench.

Secure the laterals using the new hardware provided in kit. **Fig. 123**



Hip Guide Width	
Model Size	Width Range
12	9"-12"
13	10"-13"
14	11"-14"
15	12"-15"
16	13"-16"

To Adjust:

Adjust the hip guides to desired width **Fig. 124, 125** by removing the hardware shown on **Fig. 126**

Secure the hip guides with hardware and attach seat cushion **Fig. 126**

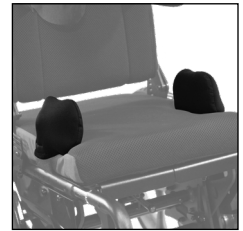

Fig. 126

Medical Knee Abductor (Pommel)

Installation/Removal

1. Align pommel bracket with receiver on seating module. **Fig. 127**
2. Fully insert bracket into receiver until bracket is touching seat cushion. **Fig. 128**
3. Tighten hand knob firmly to fully secure pommel in place. **Fig. 129**
4. To remove repeat steps 1-3 in reverse order.



Fig. 127



Fig. 128



Fig. 129

Adjusting the Height

1. While installed, use a 7/16" wrench to loosen the two horizontal facing nuts. **Fig. 130**
2. Adjust to desired height and retighten nuts.

Adjusting the Depth

1. While installed, use a 7/16" wrench to loosen the two vertical facing nuts. **Fig. 130**
2. Adjust to desired depth and retighten nuts.

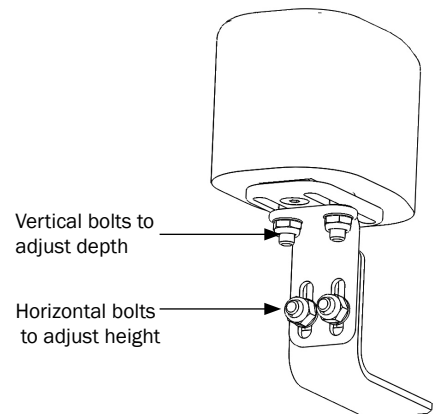

Fig. 130

Canopy Attachment

Adjustable Canopy:

1. Align canopy retaining clips with frame of the chair. **Fig. 131**
2. Push on the clips with the ball of your hand until they snap into place. **Fig. 132**
3. To open, grasp top of canopy and push forward and rotate downward. **Fig. 133**



Fig. 131



Fig. 132



Fig. 133

Oxygen Tank Holder

How to Hang the Oxygen Tank Holder

1. Remove the two frame bolts located on the left side of the frame with 5/32" Allen wrench. **Fig. 134**
2. Slide the oxygen tank holder in place. **Fig. 135**
3. Re-install the frame bolts with 5/32" Allen wrench.



Fig. 134



Fig. 135

How to Secure Oxygen Tank

1. Place tank onto the bottom lip of the oxygen tank holder.
2. Secure the upper strap by buckling tight at both the midpoint and bottom of tank. **Fig. 136**
3. Confirm the straps are secure. **Fig. 137**



Fig. 136



Fig. 137

Attaching LTV Bracket

1. Loosen 2 bolts on right curved side frame tube.
2. Slide the tank holder hook over curved side frame tube.
3. Align left and right slots of LTV vent holder with left and right bolts on left hand side of frame. **Fig. 138**

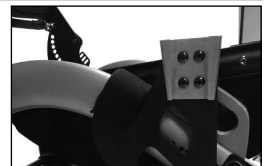

Fig. 138

LTV Vent Holder

1. Align male dovetail bracket located on ventilator with female dovetail bracket located on LTV holder bracket. **Fig. 139**
2. Slide down and lock securely into bracket. **Fig. 140**
3. Attach ventilator.



Fig. 139



Fig. 140

Elevating Leg Rest

To Adjust Height:

Place your hand on the grey button located at the knee joint. **Fig. 141**

1. Press the grey button to adjust lower extremity to desired angle and release button.



Fig. 141

Ventilator/Suction/Hard Tray

The hard tray has two independent height settings and five independent width settings.

To Install:

1. Remove fixed front riggings, or elevate elevating leg rest, depending on which the chair is equipped with.
2. Slide the tray through bottom of the chair frame.
3. Align the rear hook with the brake tube. **Fig. 142**
4. In one motion, attach the rear hooks onto the brake tube and the front hook to each side of the guide plate.
5. Secure the tray by looping the Velcro® strap around the brake tube.



Fig. 142

To Remove:

1. Remove fixed front riggings, or elevate elevating leg rest, depending on which the chair is equipped with.
2. Remove the Velcro® strap and reverse the steps.

To Adjust the Height of the Tray:

1. Remove the height adjustment hardware (circled in **Fig. 143 & 144**) with 5/32" Allen wrench and 7/16" wrench. **Fig. 143 & 144**
2. Adjust to desired height and tighten hardware.

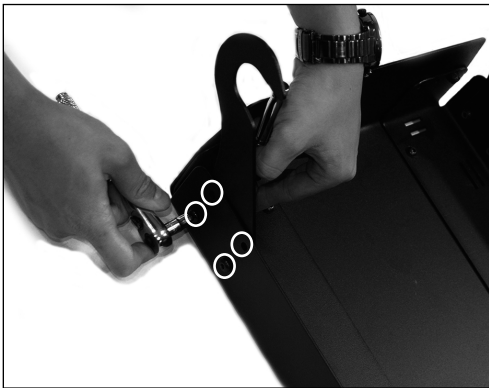

Fig. 143

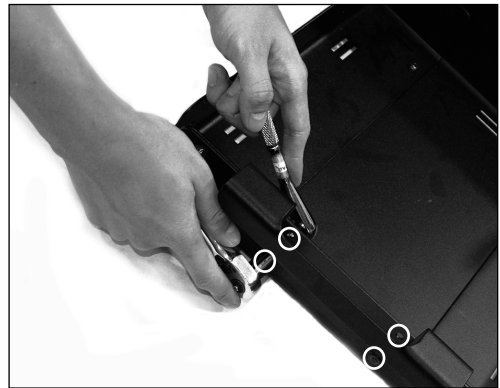

Fig. 144

To Adjust the Width of the Tray:

1. Remove the width adjustment hardware (circled in **Fig. 145 & 146**) with 5/32" Allen wrench and 7/16" wrench.
2. Adjust to desired width and tighten hardware.

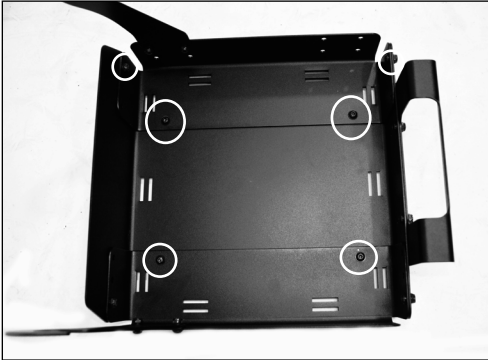

Fig. 145



Fig. 146

Ground Clearance (for back maintenance, operating & safety instructions):

Small wheels + Min height setting = 2.5" (63.5mm)

Small wheels + Max height setting = 1.3" (33.0mm)

Large wheels + Min height setting = 4.5" (114mm)

Large wheels + Max height setting = 3.3" (84.0mm)

Rear Anti-Tip Tubes

1. To install the anti-tip tube, align the tube with the end of the round mobility base tubing located next to the rear wheel. **Fig. 147**
2. Push the spring button while positioning the anti-tip into the round mobility base tubing, and then push until the “release button” pops through the hole located on the anti-tip tube. **Fig. 148**
3. Repeat steps 1 & 2 for opposite side.
4. To remove the anti-tip tubes, perform steps 1-3 in reverse order.



Fig. 147



Fig. 148

Curb Tipper

1. To install the curb tipper tube, align the tube angled upwards with the end of the round mobility base tubing located next to the rear wheel. **Fig. 149**
2. Push the spring button while positioning the curb tipper tube into the round mobility base tubing, and then push until the “release button” pops through the hole located on the curb tipper tube. **Fig. 149**



Fig. 149

Transit Models

Transit Option

The wheelchair transport model has been crash tested and complies with the requirements of RESNA WC4:2012 section 19. Dummy weights are:

Flyer Models	Back Cane Position	Weight Capacity
FL12T/13T/14T/15T/16T	Position 1	85 lbs./39 kg
FL12T/13T/14T/15T/16T	Position 2/3/4	170 lbs./75kg

The Flyer provides for anchoring of a crashworthy pelvic-belt restraint that conforms to requirements of RESNA WC-4, and that can be used in conjunction with a vehicle-anchored shoulder belt with a standard lower anchorage connector for effective crashworthy three-point belt restraint in a motor vehicle. To reduce possibility of injury, the head support must always be used with the chair.

The following instructions should be followed to minimize impact in case of a crash:

1. During transit, the chair must be forward facing. All non-essential accessories should be removed.
2. Use only a tested, proven and compatible 4-point wheelchair tiedown system (WTORS) and a 3-point occupant restraint system in accordance with WC4-18.
3. The wheelchair tiedowns must be securely attached to the four red anchor points on the chair. See arrows for anchor points. **Fig. 150 & 151**
4. The occupant restraints must include a lap and shoulder belt, secured directly to the Flyer mobility base and the vehicle.
5. All floor tiedown straps must be drawn tight in the front and the back to eliminate any forward/aft movement of the chair.
6. Wheelchair restraint manufacturers' instructions must be followed precisely to ensure intended performance.



Fig. 150



Fig. 151

Wheelchair Lateral Stability and Belt Restraint Accommodation Rating

Wheelchair Model	Mass (Weight) of Wheelchair (lb./kg)	Test Rating	Lateral Stability* (in./mm)
FL Position 1-4 Large (16") Rear Tire	32.5/14.75	Acceptable	0.75/19.2
FL Position 1-4 Small (11.5") Rear Tire	29.2/13.25	Acceptable	0.79/20.1

* "Lateral stability" is the displacement of point P (the center of gravity on the loaded wheelchair) when a platform with the loaded wheelchair is tilted 45° laterally from the horizontal. Higher numbers indicate less stability.

This table refers to tests performed in accordance with WC19 to establish lateral stability during normal travel and the ease of use and proper fit of vehicle-anchored belt restraints.

Transportation Mode Instructions

Using the Flyer Chair for Transportation in Motor Vehicles

The Transit Model Flyer is for transporting users in motor vehicles when it is equipped with the OPTIONAL Transit feature and used in accordance with these instructions. The chair MUST be secured in a forward-facing position with Wheelchair Tiedown and Occupant Restraint Systems (WTORS), which meets the requirements of WC-4: section 18. Recommended Practice—Wheelchair Tiedown and Occupant Restraint Systems For Use in Motor Vehicles.

IMPORTANT INFORMATION:

This transit option conforms to and has been dynamically tested in accordance with RESNA WC-4:2012 Section 19 (WC19).





WARNING: Pelvic and belt restraint should be used to limit occupant movement.





WARNING: Flyer was dynamically crash tested in a forward-facing position using an appropriately sized crash-test dummy restrained by both upper-torso (shoulder) and lower-torso (lap) belts. To reduce the possibility of head and chest injuries resulting from contact with vehicle components, you must use both upper and lower torso belts.

 **WARNING:** Both pelvic and torso restraint belts must be used while traveling aboard a motor vehicle.

 **WARNING:** Do not alter or substitute any part or component of the wheelchair, wheelchair frame or wheelchair seating system.

 **WARNING:** Do not attach tiedowns anywhere except designated tiedown locations.

 **WARNING:** Do not use the chair if it has been involved in a crash. In the event that your Flyer is involved in a crash, please contact the Convaid Service Dealer or Convaid Customer Service Representative in order to arrange an evaluation of your Flyer.

 **WARNING:** Do not overtighten as this may cause damage to the mobility base.

 **WARNING:** During transit, chair must be forward facing with the seating module in the forward facing position on the mobility base. All non-essential accessories should be removed.

 **WARNING:** The wheelchair should be used as indicated in the User's Guide instructions accompanying the wheelchair. Failure to do so increases the likelihood of serious injury in a vehicle crash.

 **WARNING:** A three-point occupant restraint and a four-point wheelchair tie-down system in compliance with SAE J2249/WC-4:2012 Section 18 Wheelchair Tie-down and Occupant Restraint Systems for Use in Motor Vehicles should be used at all times during transit.

 **WARNING:** Use positioning belts or postural supports in a moving vehicle only in conjunction with a crash-tested belt restraint system. NEVER USE POSITIONING BELTS OR POSTURAL SUPPORTS AS MOTOR VEHICLE RESTRAINTS, unless they have been designed, tested, and labeled for this use.

 **WARNING:** The Upper Extremity Support Surface (Tray) with flip-up armrests are not recommended to be used in transport.



WARNING: Wheelchair-anchored lap belts intended for use as an occupant restraint in a motor vehicle must comply with Section 19 ANSI/RESNA WC/ Volume 1, and WC-4:2012 Wheelchairs Used as Seats in Motor Vehicles, or “WC19.” Your Convaid transit wheelchair provides the option of using a crash-tested, wheelchair-anchored lap belt.



WARNING: Adequate clear zones are required for occupants restrained by both upper and lower-torso belt restraints. See **Figs. 158 & 159**



WARNING: Do not use the chair if it has been involved in a crash. In the event that your wheelchair is involved in a crash, please contact the Convaid Service Dealer or Convaid Customer Service Representative in order to arrange an evaluation of your wheelchair.



WARNING: While the wheelchair is in transit, wheel locks must be engaged and the wheelchair must be in forward facing position.



WARNING: Wheelchair-mounted hard trays that are not specifically designed for use during travel in motor vehicles should be:

- Removed and secured separately in the vehicle, or
- Secured to the wheelchair so they will not break free in a crash, and
 - Be positioned with a gap of at least 3 inches between the edge of the tray and the wheelchair occupant’s abdomen and/or chest so as not to interfere with proper belt restraint use, and
 - Be used with energy absorbing padding placed in the gap between the tray edge and the wheelchair occupant.



WARNING: Vehicle interior components that cannot be removed from the clear zones of Figure 1, or that are on the outboard side of the wheelchair occupant space at a level that may be contacted by a wheelchair occupant’s head during a collision or vehicle rollover, should be padded with material that complies with FMVSS 201.



WARNING: Back supports of occupied wheelchairs with adjustable angles should not be reclined to more than 30° to the vertical, during travel, unless necessary.

RECOMMENDED CLEAR ZONES IN VEHICLE

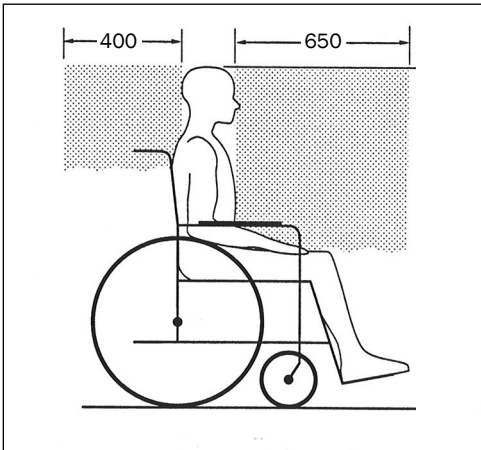

Fig. 152 Side View

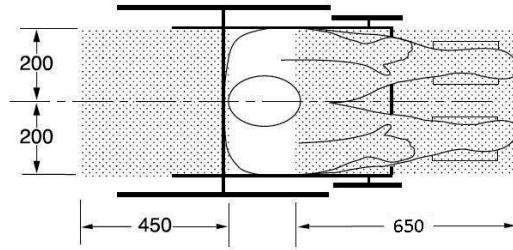

Fig. 153 Top View

The rear clear zone is measured from the rearmost point on an occupant's head. The front clear zone is measured from the frontmost point on an occupant's head.

NOTE: Dimensions are shown in millimeters.

Securing the Wheelchair

Attach tiedown straps to transit anchors located on the wheelchair's mobility base and seating module in accordance with the WTORS manufacturer's instructions. Securement points are identified by the symbol in **Fig. 154**, and their location on the wheelchair illustrated in **Fig. 155 & 156**

WARNING: While the wheelchair is in transit, wheel locks must be engaged and the wheelchair must be in forward facing position.

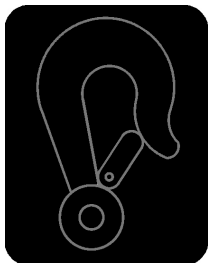

Fig. 154



Fig. 155

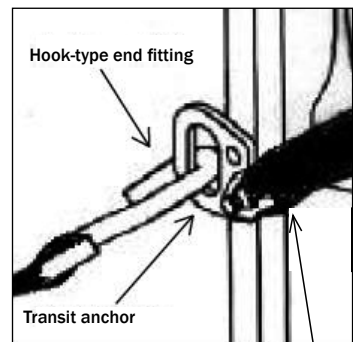
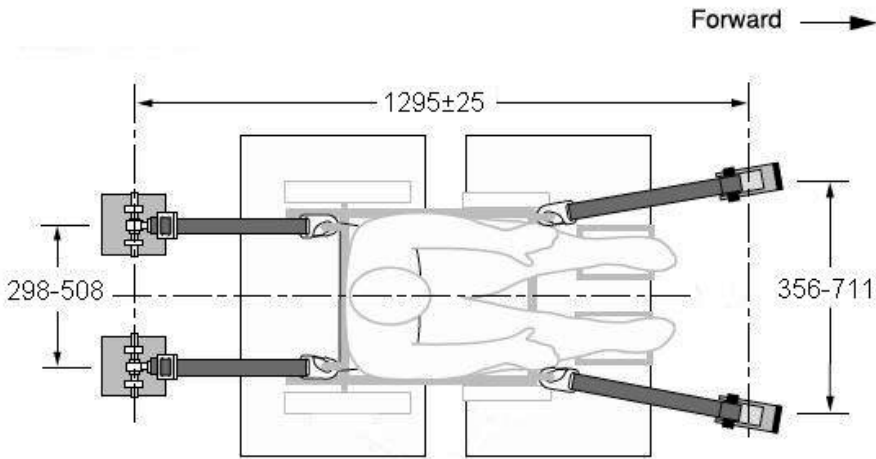

Fig. 156

Lap belt anchorage

PREFERRED ANGLES OF FRONT AND REAR TIE-DOWN STRAPS (TOP) AND PREFERRED LOCATIONS OF FLOOR ANCHOR POINTS (BOTTOM).



NOTE: Dimensions are shown in millimeters

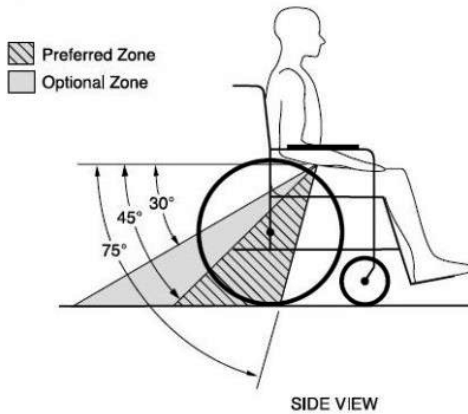

Fig. 157

Fig. 158 FRONT TIEDOWN STRAPS ANGLED AWAY FROM SIDES OF WHEELCHAIR.

Fig. 159 CORRECT POSITIONS OF SHOULDER AND LAP BELT RESTRAINTS AND WHEELCHAIR TIEDOWNS.

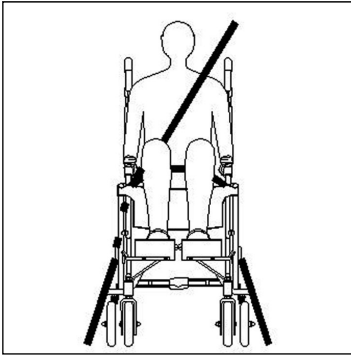

Fig. 158



Fig. 159

STANDARD METAL CLIP (**Fig. 160**) AT LOWER END OF SHOULDER BELT AND AT END OF OPTIONAL WHEELCHAIR-ANCHORED LAP BELT USED TO CONNECT TO PIN/BUSHING (**Fig. 161**) ON LAP BELT OR ON WHEELCHAIR SECUREMENT POINT BRACKETS.

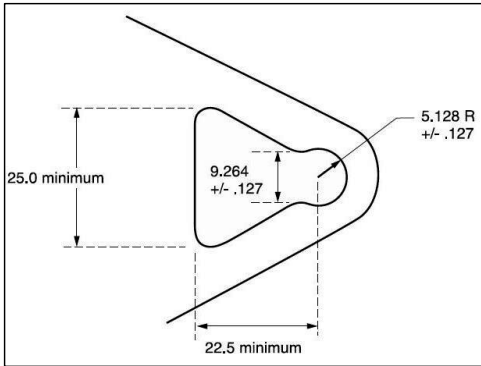

Fig. 160

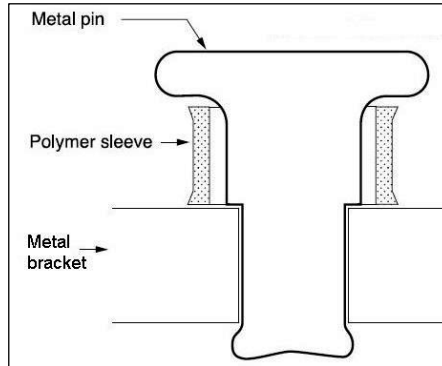

Fig. 161

Dimensions shown in inches

Providing Clear Space & Padding

Position the wheelchair aboard the motor vehicle to ensure sufficient clear space in front of, and behind, the occupant. (See **Figs. 152 & 153**) If there are any hard or sharp objects or components near the wheelchair, such as components of lifts or fold-up seats, they must be covered with heavy-duty energy-absorbing padding to ensure the safety of the wheelchair occupant and other passengers.

Restraining the Wheelchair Occupant

Your Convaid transit wheelchair was dynamically crash tested in a forward-facing configuration using an appropriately sized crash-test dummy restrained by both upper-torso (shoulder) and lower-torso (lap) belts. To reduce the possibility of head and chest injuries resulting from contact with vehicle components, you must use both upper and lower torso belts. (See **Figs. 158 & 159**)

Your Convaid transit wheelchair provides for the use of an optional wheelchair-anchored lap belt. The optional belt, which has been dynamically tested in accordance with Annex A of WC19, may be ordered from Convaid at a nominal additional cost. To attach the lap belt to the wheelchair, secure the metal clips at the ends of the lap belt (**Fig. 160**) to the pin/bushing connectors located on the wheelchair's rear securement-point brackets. (**Fig. 161**)

Before loading the wheelchair onto the vehicle lift, fasten the lap belt over the wheelchair user's pelvis. The wheelchair user should wear the optional lap belt as low over the pelvis and as snugly as possible without compromising comfort. The vehicle-anchored shoulder belt may then be clipped to the pin/bushing connector located on the lap belt near where it attaches to the chair. When not in use, the optional lap belt may be looped underneath the seat, buckled, and tightened.

If the wheelchair is purchased without the optional lap belt or if the wheelchair user elects not to use the belt, a vehicle-anchored lap and shoulder belt must be used. As with the wheelchair-anchored lap belt, it is very important to position the vehicle-anchored lap belt low over the pelvis so that the angle of the lap belt is within the preferred zone of 45° to 75° to the horizontal or the optional zone of 30° to 45° to the horizontal, as shown in **Fig. 164**. Be sure that the shoulder belt crosses the chest and the middle of one shoulder and that belt restraints are not held away from the body by wheelchair components or parts, such as armrests or wheelchair legs. (**See Fig. 165**) Thread the lap belt under the frame tubes located directly under the user's elbows and pull the belt snug against the pelvis. Ensure that belt webbing is not twisted as this may compromise safety.

Tilt-in-space wheelchairs can also be used for seating aboard a motor vehicle. It is best for tilt-in-space wheelchairs to be transported with the seat in a relatively upright orientation. However, if the seat must remain in a tilted position for medical reasons, the seat back should not be reclined more than 30 from the vertical. If it is necessary to recline the seat more than 30, move the shoulder belt anchor point rearward on the vehicle wall so that the shoulder belt remains in contact with the wheelchair user's shoulder and chest.

Using Postural Belts & Supports

Positioning accessories such as pelvic positioning belts, anterior trunk supports, and lateral trunk supports may be used while in transit, but are not designed to provide restraint during a crash. Postural supports and belts should therefore not be relied on for restraint in a vehicle crash and should be used only in conjunction with lap and shoulder belts that have been designed for restraint in a motor vehicle and crash tested in accordance with SAE J2249/WC-4:2012 Section 18 and/or ANSI/RESNA WC19.

PREFERRED AND OPTIONAL ANGLES OF PELVIC (LAP) BELT RESTRAINTS.

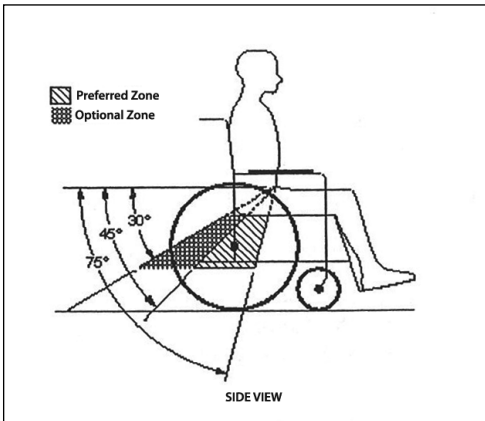

Fig. 162



Fig. 163

Note: Steeper side view pelvic-belt angles are especially important if the pelvic belt is intended to be used for postural support in addition to occupant restraint in a frontal crash. Steeper angles will reduce the tendency for a vertical gap to develop between the user and the belt due to compliance of seat cushions and belt movement, thereby reducing the tendency for the user to slip under the belt for the belt to ride up on the soft abdomen during normal use.

Note: Steeper belt angles also reduce the tendency for upper-torso belts to pull the pelvic belt onto the abdomen during frontal impact loading.

Trays & Other Wheelchair Components



WARNING: To reduce the risk of potential injury to the wheelchair user or other occupants in a motor-vehicle crash, wheelchair-mounted accessories, such as trays and respiratory equipment, must be removed and secured separately during transit. Use tether straps or other strong attachment hardware to prevent items from breaking loose and causing injury during a crash. If it is absolutely necessary to keep a tray on the wheelchair during transit, energy-absorbing padding must be placed between the edge of the tray and the wheelchair user or serious injury may result during a crash.

WTORS Manufacturers

Convaid is a wheelchair manufacturer and does not offer wheelchair tiedown and occupant restraint systems (WTORS). However, products that comply with current WTORS standards can be obtained from the following companies that specialize in crash-tested WTORS:

Q'Straint, Sure-Lok, Unwin and Ortho Safe specialize in crash-tested tiedown systems and are in no way associated with Convaid.

Ortho Safe Systems
P.O. Box 9435
Trenton, NJ 08650 U.S.A
(609) 587-9444

Q'Straint
5553 Ravenswood Rd. #110
Ft. Lauderdale, FL
33312 U.S.A
(954) 986-9987

Sure-Lok
400 S. Greenwood Ave. #302
Easton, PA 18045
U.S.A (866) 787-3565

Unwin Safety Systems
Unwin House
The Horseshoe Coat Road,
Martock, TA12, 6EY U.K.
(44) (01935) 827740

Troubleshooting Guide

Troubleshooting

Seat Bottom Tilt Adjustment Lever

Before attaching the Seating Module to the frame, check if the Tilt Adjustment Lever cable has been correctly aligned and seated inside the adjustment barrel.

To Adjust:

1. Plug the cable end into the adjustment barrel on the bottom of Seating Module.
2. Make sure the chrome cable end is fully seated inside adjustment. **Fig. 164**



Fig. 164



WARNING: The cable on the tilt adjustment lever may be pulled loose or dislodged during transport and/or initial assembly. Please check the following cable position. **Fig. 167**

Plug the cable end into the adjustment barrel. Make sure the chrome cable end is fully seated inside adjustment barrel. **Fig. 166**



Fig. 165



Fig. 166

.....



Convoid Products, LLC

2830 California Street, Torrance, CA 90503, USA

Toll free in the US: 1-844-US-Mobility (844-876-6245) • Phone: (310) 618-0111 • Fax: (310) 618-8811

Email: convoidsales.us@etac.com • International Email: international.convoid.us@etac.com

www.etac.us.com

.....