

ENGLISH

# *User's Guide*

## ***Convoid Trekker***<sup>®</sup>

Lightweight Tilt-In-Space Wheelchair



READ INSTRUCTION BEFORE USING

SAVE THIS BOOK FOR FUTURE REFERENCE

 **Convoid**

by Etac

---

# Customer Service Support

Toll Free: 1-844-US Mobility (844-876-6245)

Phone: (310) 618-0111

Fax: (310) 618-8811

Email: [convaidsales.us@etac.com](mailto:convaidsales.us@etac.com)

International Email: [international.convoid.us@etac.com](mailto:international.convoid.us@etac.com)

Website: [www.etac.us.com](http://www.etac.us.com)

Technical assistance or repair information hours are:

Monday-Friday, 6 a.m. to 4:30 p.m. PST

## Before Calling:

**Please fill in the following. Customer Service will be able to help you more quickly if the information indicated below is readily available.**

**Serial number of chair:** \_\_\_\_\_

**Model of chair:** \_\_\_\_\_

**Date purchased:** \_\_\_\_\_

**Notice:** The information contained in this document is subject to change without notice.

No part of this document may be photocopied, reproduced, transmitted, transcribed, stored in a retrieval system or translated to another language or computer language, in any form or by any means, electronic, mechanical, magnetic, optical, chemical, manual or otherwise without the prior written consent of Convoid.

## Indications for Use

The Convoid Trekker models are manual wheelchairs; they are intended to provide mobility to person with disabilities who are partially or permanently non-ambulatory and limited to a sitting position.

In addition, the Trekker transit models have been tested and comply with the requirements of RESNA WC4 Section-19:2012 and ISO 7176-19:2008, "Wheelchairs used as seating in a motor vehicle".

## Intended Use

Convoid's Trekker series are a lightweight ridge high-strength aluminum and steel manual wheelchair with optional removable seat pan for everyday indoor and outdoor use on flat firm terrain.

These persons typically have some form of neuromuscular disorder that limits their ability to self-propel such as Cerebral Palsy.

Note: The end user of all Convoid attendant propelled wheelchair products is not determined by age but by body dimensions and mass. Please read and follow all warnings carefully to insure the safety of the user.

© Copyright 2021 by Convoid. All rights reserved.

---

# **Table of Contents**

## **Product Overview**

Definition of Symbols.....	1
Warnings.....	3
Product Overview.....	6
Specifications.....	14

## **Setting Up**

Contents in the box.....	15
How To Remove Chair from box.....	15
Preparing the Chair for Use.....	15
Push Handle Adjustment.....	16
Wheel Lock Operation.....	16
Unfolding the Chair .....	17
Folding the Chair.....	18
Folding/Unfolding the Seating Module.....	21
Lifting/Carrying the Seating Module.....	21
Lifting/Carrying the Chair Mobility Base.....	22
Installing Seating Module in Forward Configuration.....	23
Installing Seating Module In Reverse Configuration.....	24
Removing Seating Module from Mobility Base.....	26

## **Fitting Guide**

Back Height.....	27
Back Height Adjustment.....	27
Seat Depth Adjustment.....	28
Seat Width Adjustment.....	29
Hip Guides w/ Armrest.....	29
Laterals.....	31
Tilt-in-Space Adjustment.....	32
Recline Adjustment.....	33
Pelvic Positioning Belts.....	34
Two-Point Positioning Belt.....	34
Three-Point Positioning Belt.....	34
H-Harness with Padded Covers.....	35
Extended Strap Vest (Butterfly Harness).....	35
Footplate Height Adjustment.....	36
Individual Footplates.....	37
Footbox Cover.....	38
Foot Positioners.....	39

## **Wheels**

Wheels Specifications.....	40
Removal & Installation of Rear Wheels.....	40

---

## Accessories & Options

---

Medical Necessity Storage Basket . . . . .	41
Ventilator / Suction Hard Tray . . . . .	41
Head Support . . . . .	42
Adjustable Headwing Headrest . . . . .	42
Universal Bracket . . . . .	43
Anatomic Headrest . . . . .	44
Canopy Bracket Installation . . . . .	46
Canopy Attachment . . . . .	47
Oxygen Tank Holder . . . . .	47
I.V Pole . . . . .	48
Elevating Leg Rest (Option) . . . . .	49
Medical Knee Abductor (Pommel) . . . . .	49
LTV Vent Holder . . . . .	50
Anti-Tip Tubes . . . . .	50
Curb Tipper . . . . .	51
Caster Locks . . . . .	52
Utility Bag . . . . .	52
Shoe Holders . . . . .	52
Upper Extremity Support Tray . . . . .	53
Calf Panel . . . . .	53

---

## Transit Models

Transit Option . . . . .	54
Transportation Mode Instructions . . . . .	55
Recommended Clear Zones in Vehicle . . . . .	57
Providing Clear Space & Padding . . . . .	57
Proper Use of Equipment . . . . .	58
Restraining the Wheelchair Occupant . . . . .	61
Using Postural Belts & Supports . . . . .	62
Trays & Other Wheelchair Components . . . . .	63
WTORS Manufacturers . . . . .	63

---

## Important Information

Maintenance, Operating & Safety Instructions . . . . .	64
--	----

---

## Troubleshooting

Trekker Mechlock Assembly . . . . .	70
Tilt Adjustment Lever . . . . .	71
Warranty . . . . .	Back Cover

---

## READ BEFORE USE

Read user's guide completely before use and fully understand its content. Familiarize yourself with the handling and functions of the product before use and practice them. Any caregiver that is going to operate this chair should also read the user's guide in full.

You are responsible for the safety of the user. The safety of the user could be affected if you do not follow the instructions in this user's guide. Nevertheless, not all possible circumstances and unpredictable situations can be covered by this user's guide. Reason, care, and circumspection are not features of the product; they are required of persons who use the product. If instructions are not clear and further explanation is necessary, please contact your Convaid provider. If you do not follow all instructions and warnings, damage to the chair or serious injury may occur. The latest version of all instructions and product safety notice are available on the Convaid website ([www.etac.us.com](http://www.etac.us.com)) and can be printed in larger sizes. Additional video instructions are also available for reference purposes.

## DEFINITION OF SYMBOLS



### WARNING!

The word "WARNING" and/or the symbol shown above indicates practices that are unsafe or dangerous and could result in serious injury or death to the occupant of this chair or others.



### WARNING! READ USER'S GUIDE!

Additional symbols are defined throughout this user's guide along with operating instructions.



This symbol indicates potential finger entrapment.



This symbol indicates correct lifting points for safe moving and handling.



This symbol indicates manufactured date.



This symbol indicates maximum user's weight.



This symbol indicates a wheelchair which cannot be used in motor vehicle as vehicle seat. This wheelchair does not comply with WC19 (RESNAWC-4:2012 or ISO7176-19:2008) and cannot be used as a vehicle seat to transport the user in a vehicle.



This symbol indicates a wheelchair which can be used in motor vehicle as vehicle seat. This wheelchair complies with WC19 (RESNAWC-4:2012 and ISO7176-19:2008) and can be used as a vehicle seat to transport the user in a vehicle.




This symbol indicates the position of an anchor point when using a 4 -point tiedown system (WTORS) during transit.


## CHOOSE THE RIGHT CHAIR & SAFETY OPTIONS

There are several options available to meet the needs of the wheelchair user. Make sure that your (and your health care provider's) choice of chair and other added options takes into account the user's comfort, positioning, physical limitations, and hazards that may be encountered during daily use. Operating the manual wheelchair outside of the recommendations provided by the manufacturer can lead to a dangerous situation.


The wheelchair is not suitable for jogging, running, skating or similar activities. Swiveling front wheels tend to wobble at higher speeds and can cause a sudden stop, and the wheelchair can tip over. Use the wheelchair only at regular walking speed. Under no circumstance should you let go of the push handle while pushing.


## General Warnings


 **WARNING:** The operator/caregiver must read and understand this user's guide prior to operating this equipment. If you are unable to understand any part of the user's guide, contact your supplier for assistance.


 **WARNING:** Never exceed the maximum occupant weight capacity indicated on the serial number label on the seating module. When using the chair in transit, all non-essential accessories must be removed from the chair and secured separately.


**WARNING:** To reduce the risk of an accident:


- 
- ALWAYS carefully read the User's Guide and get comfortable operating the chair.
  - ALWAYS watch for obstacles and avoid them as often as possible.
  - MAKE SURE that the chair operates properly. Repair any problems before use.
  - ALWAYS verify that the quick release axles are locked so that the back wheels do not come off.
  - ALWAYS secure the user into the chair during use.

 **WARNING:** Positioning belts should never be used as a safety restraint device in a motor vehicle when transporting chair with occupant. An additional WC19 compliant automotive type seat belt is required when the chair is used in transport vehicles.


 **WARNING:** Changes & Adjustments  
Adjustments made to the chair will change the balance and function of the chair and may increase risk of tip over — consult your Convaid Service Dealer before making adjustments. Warranty will be voided if modifications that change the structure of the mobility base of the chair are made without manufacturer's authorization.


 **WARNING:** The chair should only be used on flat, firm terrain.


 **WARNING:** Do not go up or down stairs without the assistance of another person or with user in the chair. If devices such as ramps or elevators are available, please use them. If they are not available, then the chair should be carried over the obstacle by two people without the user in the chair.


 **WARNING:** Pay particular attention when on slopes and inclines to prevent:


- The user from falling out of the chair.
- The chair from tipping over.
- The chair from rolling away.


 **WARNING:** Accessories that can be removed without any tools will not cause adverse effects on the chair.


 **WARNING:** Before removing the user from the chair and before returning the user to it, always engage the wheel lock. Never remove or place user without engaging the wheel lock.


 **WARNING:** Never leave the user unattended in the chair even when they are strapped in and the wheel lock is engaged.

 **WARNING:** Do not stand on the footplate when getting into or out of the chair.









 **WARNING:** When the user reaches for objects in front, to the side, or behind the chair, be sure that they do not lean out of the chair too far since the shift in the center of gravity might cause the chair to tilt or tip over.

 **WARNING:** Please keep packaging material away from children. Plastic packaging presents the danger of suffocation.

 **WARNING:** The chair is only intended to carry one user at a time. Do not carry more than one user at a time.

 **WARNING:** Whenever you change a setting on the chair, make sure that you firmly tighten any screws or knobs that have been loosened prior to placing the user in the chair.



-  **WARNING:** Motor vehicle safety – The seating module is not designed, tested or intended to be used as a car seat. Never use the seating module as a car seat. Transfer the user from the chair to an approved motor vehicle adaptive car seat. If your chair is equipped with the transit option, refer to the transit section in this user's guide regarding use of this chair for transit.
-  **WARNING:** Never use this chair on an escalator because the chair may tip over.
-  **WARNING:** Many of the screws, bolts, and nuts used on this chair are specialized or high-strength fasteners. Only use fasteners purchased through Convaid or a Convaid service dealer.
-  **WARNING:** Do not use the chair unless it has proper tire pressure. (Front 36 psi/ Rear 30 psi, 248kPa/200kPa, 2.5BAR/2.0BAR) Do not over inflate the wheels. Failure to follow these instructions may cause the chair wheels to explode and cause harm. Tire size and maximum pressure as listed on the wheels.
-  **WARNING:** During transit, the chair must be forward facing with the seating module in the forward facing position on the mobility base with all accessories removed.
-  **WARNING:** The chair could lose its flame resistant characteristics when combined with aftermarket seating or cushion.
-  **WARNING:** Do not leave/store the chair in direct sun/heat over a long period of time. Check the temperature of the chair prior to usage.
-  **WARNING:** When using the Trekker 12 or Trekker 14 back canes seating module in reverse configuration and set to seat depth position 1, the recline adjustment of 80° combined with -10° anterior tilt may cause the chair to tip. To reduce the possibility of tipping, add anti-tips to the chair.

## PRODUCT OVERVIEW

### Trekker Mobility Base (Front View)







 2017-7-17	<b>TREKKER Base</b> S/N: TR-B-00001	 Varies		 Refer to seating module for Max Weight
<small>CONVAID 2830 California Street (310) 618-0111 Torrance, CA 90503 USA (888) 266-8243</small>				

Fig. 1

# Trekker Mobility Base (Back View)

Never leave occupant unattended. Failure to read and follow user guide instructions could result in serious injury. To obtain a replacement user's guide email [convaidsales.us@etac.com](mailto:convaidsales.us@etac.com) or call 1-844-US Mobility (844-876-6245)

Chair Warning Label

Tilt Adjustment Lever

Closure Strap

Folding Triggers

Transit Anchors (Rear)

Option

Single Foot Activated Wheel Lock Bar

Docking Platform  
Seat Lock Lever

11.5" x 2.5" Rear Solid Wheels



Fig. 2

# Trekker Seating Module Back Canes (Front View)

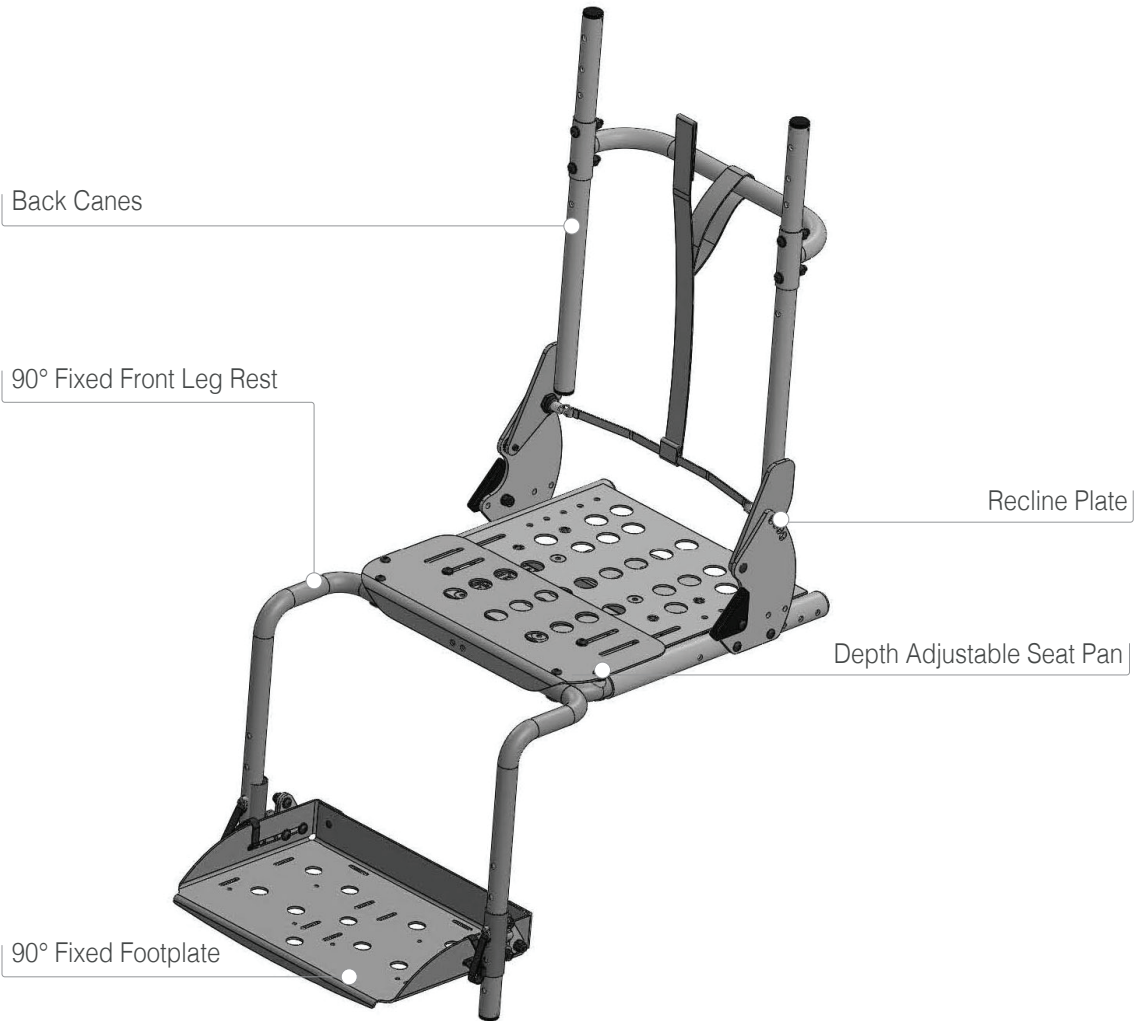
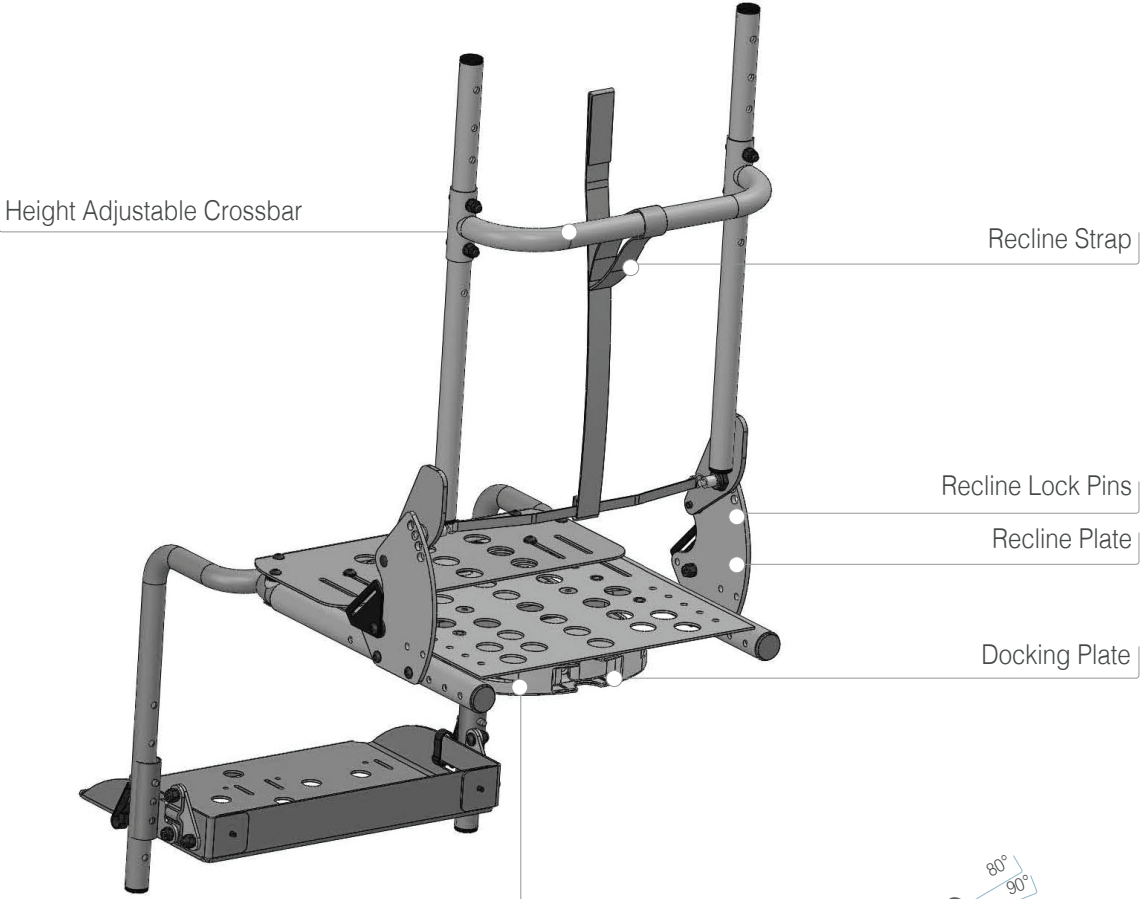


Fig. 3

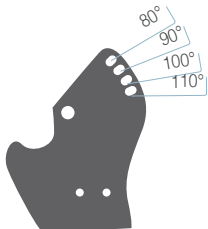
# Trekker Seating Module Back Canes (Back View)



Seating Module Serial Number Label

 2017-7-17	<b>TREKKER 12</b> S/N: TR-12-00001	 MAX 75 lbs				
<small>CONVAID 2830 California Street (310) 618-0111 Torrance, CA 90503 USA (888) 298-8243</small>						

 2017-7-17	<b>TREKKER 14</b> S/N: TR-14-00001	 MAX 110 lbs				
<small>CONVAID 2830 California Street (310) 618-0111 Torrance, CA 90503 USA (888) 298-8243</small>						



80° - 110°  
Recline Degrees  
(Standard)

Fig. 4

## Trekker Seating Module Solid Back (Front View)

Curved Head Support

Height Adjustable Solid Back Seating Module

Option

Trunk Positioning Slots

90° Fixed Front Rigging

Depth Adjustable Seat Pan

90° Fixed Footplate

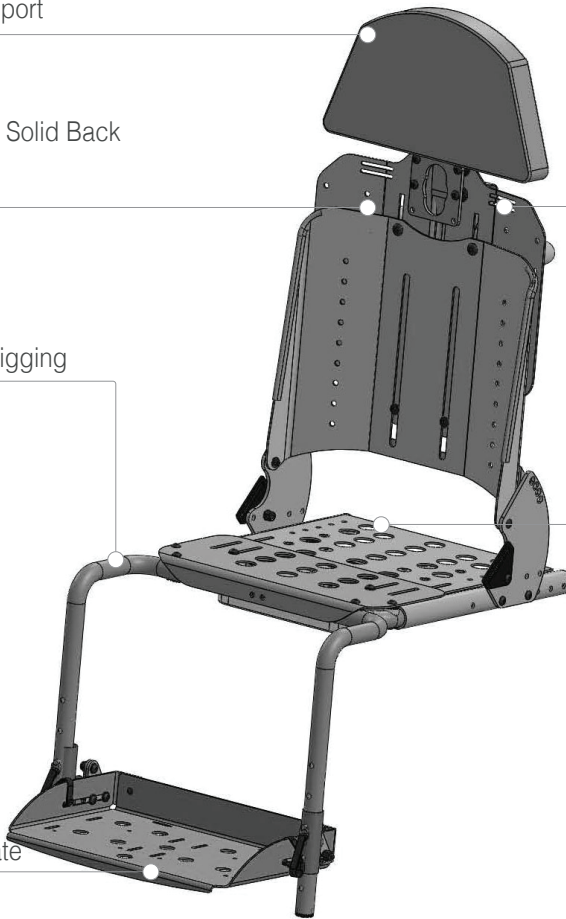
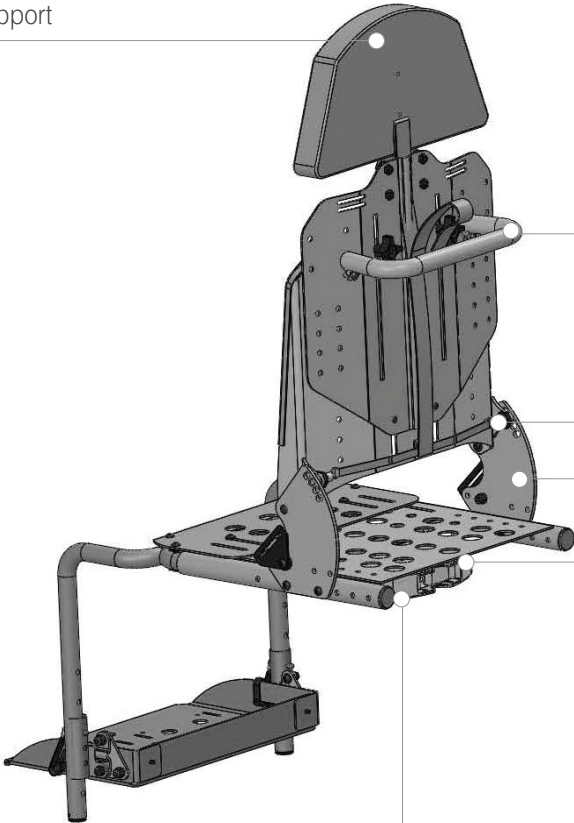


Fig. 5

# Trekker Seating Module Solid Back (Back View)

Curved Head Support



Crossbar

Recline Lock Pins

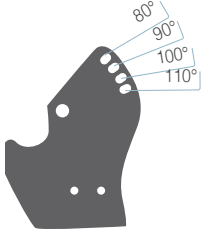
Recline Plate

Docking Plate

Seating Module Serial Number Label

 2017-7-17	<b>TREKKER 12</b> S/N: TR-12-00001	 MAX 75 lbs				
<small>CONVAID 2830 California Street (310) 618-0111 Torrance, CA 90503 USA (888) 266-8243</small>						

 2017-7-17	<b>TREKKER 14</b> S/N: TR-14-00001	 MAX 110 lbs				
<small>CONVAID 2830 California Street (310) 618-0111 Torrance, CA 90503 USA (888) 266-8243</small>						



80° - 110°

Recline Degrees  
(Standard)

Fig. 6

## R82 Stingray Seating Module

---

The R82 Stingray seating module has been tested in combination with the Convaid Trekker base. **Fig. 7**

This R82 Stingray seating module with Trekker base conforms to and has been dynamically tested in accordance with RESNA WC- 4:2012 Section 19 (WC19) and ISO 7176-19:2008

**NOTE:** For transit information, please refer to Pg. 54

**NOTE:** Please refer to R82 Stingray user's guide for seating module adjustment instruction, maintenance or safety information.

**NOTE:** All features may not be available with some device setups or in conjunction with other device features. Please consult your dealer for more information



**WARNING:** Always refer to the serial number label on the seating module for occupant maximum weight capacity.

**Stingray Seating Module weight capacity: 88 lbs.**



**Fig. 7**  
R82 Stingray Seating Module with  
Convaid Trekker Base



---

## R82 High-Low Indoor Frame

---

The R82 High Low Indoor Frame has been tested in combination with the Trekker seating modules. **Fig. 8 and Fig. 9**

**NOTE:** Please refer to the R82 High-Low Indoor Frame user guide for instruction, maintenance or safety information.

**NOTE:** All features may not be available with some device setups or in conjunction with other device features. Please consult your dealer for more information

**!** **WARNING:** Always refer to the serial number label on seating module for occupant maximum weight capacity.

**Seating Module Weight Capacity:**

Trekker 12: 75 lbs.

Trekker 14: 110 lbs.



**Fig. 8**  
R82 High-Low Indoor Frame without  
push brace (shown lowered) with  
Convaid Trekker Seating Module



**Fig. 9**  
R82 High-Low Indoor Frame with  
push brace (shown extended) with  
Convaid Trekker Seating Module

**Trekker Seating Module Specifications**

<b>Seating Module Size</b>	<b>TR12</b>	<b>TR14</b>
Seat Width	11.75"	13.75"
Seat Depth Range	7.5" - 13.5"	9.5" - 16.5"
Seat Back Height	13 - 17"	17 - 25"
Seat to Floor Height	19.8"	19.8"
Seat hip width range between hip guides without armrest:	6" - 11.5"	6.5" - 14"
Seat hip width range between hip guides with armrest:	6.25" - 11.5"	6.5" - 14"
Trunk Width Range Between Fixed Laterals	8.5" - 12"	10.5" - 14"
Trunk Width Range Between Swing-Away Laterals	6.5" - 12"	8.5" - 14"
Back Recline (Standard)	80° - 110°	80° - 110°
Back Recline (Optional)	80° - 170°	80° - 170°
Tilt Adjustment	-10 to 45°	-10 to 45°
Footplate Adjustment Angle	±15°	±15°
Seating Module Weight Capacity	75 lbs	110 lbs
Weight of Solid Back Seating Module Only	10 lbs	11.5 lbs
Weight of Back Canes Seating Module Only	8.5 lbs	10 lbs
Material (Mobility Base)	Steel / Aluminum	
Material (Plastic Parts)	Fiber glass strengthened polyamide	
Material (Cushion)	Fire-resistance foam*	
Material (Fabrics)	Fire-resistance nylon, polyester*	

\*Resistance to ignition of upholstered parts complies to BS-EN 1021-1 and -2 and WC-1 Section 16

**Trekker Base Specifications**

<b>Base Size</b>	<b>TR14</b>
Overall Height	37.5"
Overall Length	42.5"
Overall Width	26"
Maximum Slope for use of parking brakes	13°
Minimum Pivot Width	47"
Folded Length	39"
Folded Width	26"
Folded Height	13.5"
Weight of Base Only	27 lbs

# ***Chair Set Up & Adjustment***

## **Contents in the Box**

---

### **List of items included in the box:**

- Mobility Base and Seating Module
- Rear wheels (pair)
- User's Guide
- Accessories as ordered

### **Tools needed:**

- 5/32" Allen wrench
- 7/16" Wrench
- 3/8" Wrench
- Phillips Screwdriver

## **How to Remove Chair from Box**

---

1. Place box flat on the floor.
2. Verify that package is in good shape and that no damage has occurred during shipping.
3. Remove the chair from the packaging material.
4. Check to make sure that your order is complete.

## **Preparing the Chair for Use**

---

Once you have all components as ordered, the directions for use in this User's Guide will guide you through the process of preparing the chair for use:

Convaid recommends the initial fitting, adjustments, and setup take place with the help of your Convaid Representative and/or Convaid Service Dealer. However, if the instructions contained in this user's guide are followed carefully, a caregiver or attendant will be able to set up and assemble the chair.

## Push Handle Height Adjustment

---

1. To adjust the height of the one piece push handle, press the buttons on each side of handle. **Fig. 10**
2. While holding the buttons down, adjust handle up or down. **Fig. 11**
3. Release buttons to secure push handle to desired height.

**Note:** The Trekker has two push button mounting options:

1. Inside mount (shown in **Fig. 10**)
2. Outside mount



**Fig. 10**



**Fig. 11**

## Wheel Lock Operation

---

**⚠ WARNING:** Do not use excessive force or stand on wheel lock.

**⚠ WARNING:** When mobility base is in reverse position, you must tilt the seating module or adjust the elevating leg rest to maintain wheel lock clearance.

### To Lock Wheels:

Push the wheel lock downwards and roll the wheelchair slightly back or forward so that the lock pins engage into the wheel.

**Fig. 12**

### To Unlock Wheels:

To disengage the wheel lock, push the wheel lock upwards with your toe. **Fig. 13**



**Fig. 12**



**Fig. 13**

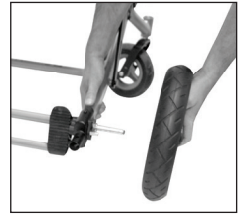
## Unfolding the Chair

### Unfolding instructions with seating module in place:

1. Unbuckle and release closure strap. **Fig. 14**
2. Install rear wheels if they have been removed, confirm that the wheels are all the way in and that you have heard the “click” confirming securement on the axle. **Fig. 15**
3. Standing behind the chair, pull on the push handle upwards and back until mobility base locks have securely locked. **Fig. 16**
4. Pull on the recline strap and bring the seat back to an upright position. **Fig. 17**
5. If Seating Module is equipped with elevating leg rest, push the buttons on the side to adjust the leg rest to a vertical position. **Fig. 18**
6. Adjust push handle as needed by pushing on the grey buttons. **Fig. 19**



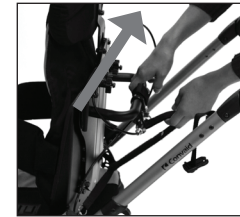
**Fig. 14**



**Fig. 15**



**Fig. 16**



**Fig. 17**



**Fig. 18**



**Fig. 19**

### Unfolding instructions without seating module:

1. Unbuckle and release closure strap. **Fig. 14**
2. Install rear wheels if they have been removed, confirm that the wheels are all the way in and that you have heard the “click” confirming securement on the axle. **Fig. 15**
3. Standing behind the chair, pull the push handle upwards and back until the push handle frame locks have secured. **Fig. 16**
4. Adjust push handle as needed by pushing on the grey buttons. **Fig. 18**

**WARNING:** Before placing the user in the chair, make sure the quick release lock is engaged and the wheels are secured.

**WARNING:** Keep fingers free of folding triggers.

**WARNING:** After Unfolding the Trekker Frame it is advised to slightly pull down on the tilt cable to prevent kinking in cable housing.

## Folding the Chair

---








-  **WARNING:** Never attempt to fold the Trekker Chair with a user in it. This could result in serious injury.
-  **WARNING:** Do not place user in the chair until you have verified that the folding action is properly locked.
-  **WARNING:** Do not allow children near the chair while folding to avoid possible pinch points.
-  **WARNING:** Make sure tilt is returned to upright position before folding.
-  **WARNING:** The Trekker Chair can be folded into a compact mode that is ideal for transport and storage. The mobility base will fold with or without the seating module installed. Folding action may be limited when positioning equipment is installed. Always properly secure the Trekker in a safe location when transporting as a cargo in vehicle.
-  **WARNING: Pinch Warning!** When docking the seating module on The Trekker Frame, DO NOT place fingers into the slots on the underside of the seating module. **Fig. 20**
-  **WARNING:** Prior to folding the Trekker Frame it is advised to slightly pull up on the tilt cable to prevent kinking in the cable housing. **Fig. 21**



Fig. 20



Fig. 21

## Folding Instructions with seating module in place:

1. Adjust the push handle downward. **Fig. 22**
2. Fold the seat back forward by pulling on the recline strap and pushing the seat back forward. **Fig. 23**
3. Pull back on folding triggers (**Fig. 24**) until the mobility base unlocks.
4. Push forward and then down on push handle. **Fig. 25**
5. Resistance will be felt when chair is folded to its limit. Do not force chair to fold further. To further reduce the folded size, the rear wheels can be removed. The wheel lock bar must be disengaged to allow removal of wheels. The chair is now ready for transport or storage. **Fig. 26**
6. Secure closure strap on the side of the chair to keep mobility base closed while transferring or lifting. **Fig. 27**



**Fig. 22**



**Fig. 23**



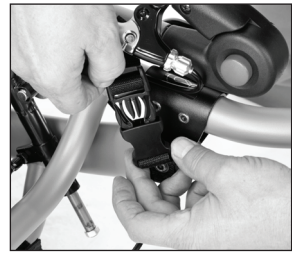
**Fig. 24**



**Fig. 25**



**Fig. 26**



**Fig. 27**

## Folding Instructions with seating module removed:

1. Pull back on folding triggers (Fig. 28) until the mobility base unlocks.
2. Push forward and then down on push handle. Fig. 29
3. Secure closure strap on the side of the chair to keep mobility base closed while transferring or lifting. Fig. 30



Fig. 28



Fig. 29



Fig. 30



**WARNING:** Risk of pinching. Be careful of possible pinch points when folding or collapsing the chair. Fig. 29-33



Fig. 31



Fig. 30



Fig. 33



Fig. 34

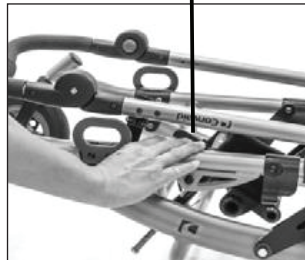


Fig. 35



## Folding/Unfolding the Seating Module

### Folding:

1. Remove user from the chair.
2. While holding the back of the push handle, pull on the recline strap. Make sure you are pulling from the center of the recline strap. **Fig. 36**
3. Fold the seat back forward, then release recline strap. Folding may be limited by positioning components and position of elevating leg rest (if equipped). **Fig. 37**

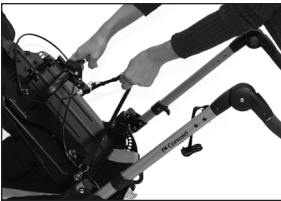


Fig. 36

### Unfolding:

1. To unfold, pull the recline strap while holding on the center of the recline strap.
2. Move the seat back to the upright position.
3. Adjust seat to back angle to desired position and release the recline strap. Check that the recline lock pins have securely locked.

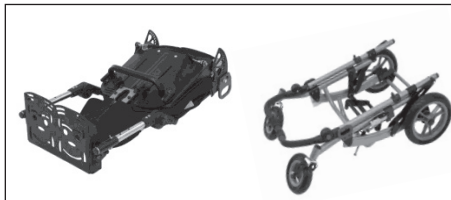


Fig. 37

## Lifting/Carrying the Seating Module

### To Lift/Carry the Seating Module:

1. To safely lift or carry the Seating Module, hold it using two hands.
2. With one hand hold the seating module by the crossbar located on the back of the seating module, with the other hand hold the leg rest. **Fig. 38**

**WARNING:** ALWAYS carry the seating module by the crossbar and the leg rest.

**WARNING:** ALWAYS check that the seating module tilt and recline mechanisms are locked in place before attempting to lift or carry the seating module.



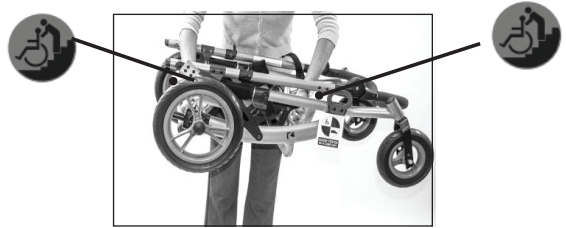
Fig. 38

## Lifting/Carrying the Chair Mobility Base

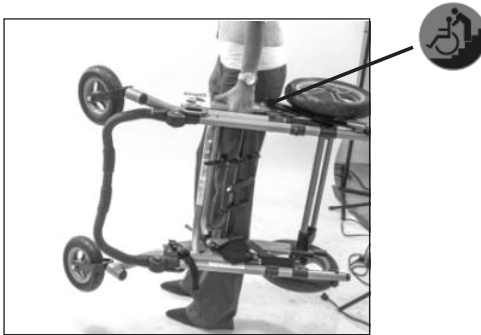
1. To safely lift or carry the Trekker, hold the mobility base with two hands. **Fig. 39**



**Fig. 39**



**Fig. 40**



**Fig. 41**

**! WARNING:** Always secure the Trekker mobility base by using the folding strap before carrying/lifting the chair. **Fig. 40**

**! WARNING:** When carrying/lifting the Trekker, please keep your hands away from folding mechanisms. **Fig. 41**

**! WARNING:** Accessories will add extra weight to the chair. Lift with caution.

## Installing Seating Module in Forward Configuration

1. On the seating module, adjust seat back angle to upright 90 degrees position by pulling on the recline strap and adjusting the seat upright. **Fig. 42**
2. On the mobility base, adjust tilt to neutral position so that the docking platform is parallel to the floor. **Fig. 43**
3. Engage the wheel lock by pushing downward on the wheel lock bar. **Fig. 44**
4. On the tilt stopper, pullout the lock pin (**Fig. 45**) and adjust the tilt stopper in the downward position. **Fig. 46**
5. Carefully lift the seating module parallel to the ground and align the docking plate with the docking platform. **Fig. 47**
6. Slide the seating module into the docking platform. Seating module will stop at the safety location (1st audible click).
7. Press down on the seat release lever (**Fig. 48**) and continue to slide the seating module inwards until seating module locks into position (2nd audible click). To verify the seating module engaged properly, slide forward or backward, the seating module should not be able to slide out of position.
8. Pull back on the seat lock lever to secure the module in place. **Fig. 49**



Fig. 42



Fig. 43



Fig. 44



Fig. 45



Fig. 46



Fig. 47



Fig. 48



Fig. 49

**⚠ WARNING:** Check proper seat module docking before placing the user in the chair.

**Note:** When seating module is removed and reinstalled back onto the mobility base, tilt adjustment lever must be down when facing forward or tilt lever must be up when in reverse configuration.

## Installing Seating Module in Reverse Configuration

1. On the seating module, adjust seat back angle to upright 90 degrees position by pulling on the recline strap and adjusting the seat upright. **Fig. 50**
2. On the mobility base, adjust tilt to neutral position so that the seat pan is parallel to the floor. **Fig. 51**
3. Engage the wheel lock by pushing downward on the wheel lock. **Fig. 52**
4. On the tilt stopper, pullout the lock pin (**Fig. 53**) and adjust the tilt stopper in the upward position. **Fig. 54**
5. Carefully lift the seating module parallel to the ground and align the docking plate with the docking platform. **Fig. 55**
6. Slide the seating module into the docking platform. Seating module will stop at the safety location (1st audible click).
7. Press down on the seat release lever (**Fig. 56**) and continue to slide the seating module inwards until seating module locks into position (2nd audible click). To verify the seating module engaged properly, slide forward or backward, the seating module should not be able to slide out of position.
8. Pull back on the seat lock lever to secure the module in place. **Fig. 57**



Fig. 50



Fig. 51



Fig. 52



Fig. 53



Fig. 54



Fig. 55

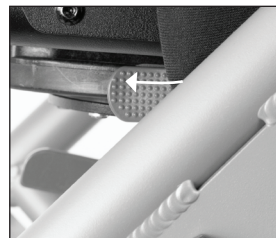


Fig. 56



Fig. 57

**! WARNING:** When using the Trekker 12 or Trekker 14 back canes seating module in reverse configuration and set to seat depth position 1, the recline adjustment of 80° combined with -10° anterior tilt may cause the chair to tip. To reduce the possibility of tipping, add anti-tips to the chair.



**WARNING:** During transit, chair must be forward facing with the seating module in the forward facing position on the mobility base with the storage basket removed.



**WARNING:** Armrest combined with a contoured seat cushion can interfere with chair mobility base during installation and removal, therefore armrest must be adjusted to the lowest width; 12”(305mm). This can be achieved by removing the additional foam inserts found in the contoured cushion and adjusting armrest inwards.



**WARNING:** Check proper seat module docking before placing the user in the chair. Check docking by moving the seat module back and forth to ensure seating module does not disengage from mobility base.



**WARNING:** When mobility base is in reverse position, you must tilt the seating module or adjust the elevating leg rest to maintain wheel lock clearance.

## Removing Seating Module from Mobility Base

**! WARNING:** Always remove the user from the chair prior to removal of the seating module from the mobility base. Removal of the seating module is only intended for facilitating lifting and transportation of the chair. The user should never be placed in the seating module if it is not properly attached to the mobility base. The mobility base should never be used without the seating module assembly properly installed.

**! WARNING:** The seating module shall NEVER be used as a car seat.

1. Engage wheel lock.
2. Remove user from the chair.
3. Adjust the seat back to upright position.
4. Adjust tilt to neutral position so that the seat pan is parallel to the floor. **Fig. 58**
5. Disengage seat lock lever (**Fig. 59**) and press down on the seat release lever. **Fig. 60**
6. Slowly slide the seating module away from the frame. Seating module will stop at the safety location. **Fig. 61**
7. Press down on the seat release lever again and pull the seating module away from the mobility base. **Fig.58**



Fig. 58



Fig. 59



Fig. 60

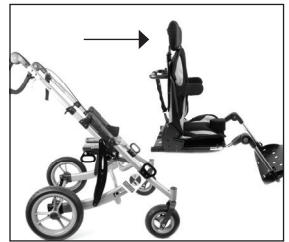
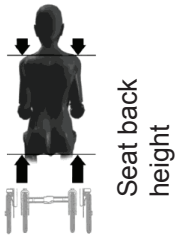


Fig. 61

# Fitting Guide

Please take the time to properly adjust the chair to fit the user. If the user is not correctly positioned, check the accessories listed in this user's guide to see if one or more of our accessories would help to facilitate posture or consult a healthcare professional. Please consult your healthcare professional or Convaid Service Dealer for additional guidance. When properly fitted, Convaid chairs will provide years of comfortable use. As the user grows, refer back to this Fitting Guide to adjust the dimensions of the chair. Convaid recommends the initial fitting, adjustments, and set-up takes place with the help of your Convaid Representative and/or Convaid Service Dealer.

## Back Height



The back height varies according to chair size. A head support is available when extra height is needed to support the head. To determine the back height, measure from the seat to the upper portion of shoulder.

**Fig. 62**

**Fig. 62**

## Back Height Adjustment

1. Loosen the two height adjustment knobs. **Fig. 63**
2. Remove back cushion as necessary. **Fig. 64**
3. Slide the back up or down carefully to desired position using the crossbar. **Fig. 65**
4. Tighten knobs and re-attach back cushion.

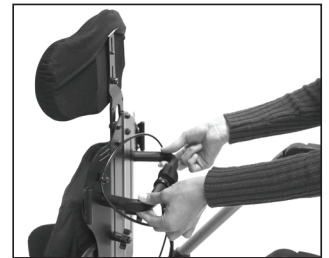
**⚠ WARNING:** Confirm that all adjustment knobs and accessories are properly tightened on the seating module before placing user back in the chair or using the chair.



**Fig. 63**



**Fig. 64**



**Fig. 65**

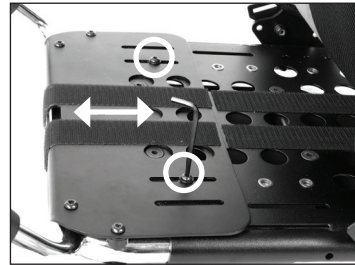
## Seat Depth Adjustment

Measure from the most posterior portion of the buttocks to the back of the knee. Subtract from that measurement 1-2" (25-51mm) to allow adequate clearance between the seat and the back of the knee. **Fig. 66**



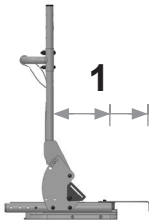
**Fig. 66**

1. Remove the user from the chair.
2. Remove seating module from mobility base and remove the cushions.
3. Set the seat back recline to 90 degrees (2nd top hole on recline plate).
4. Additional 2" of forward seat pan adjustment can be achieved by loosening the two adjustment bolts on the top of the seat pan. Use 5/32" allen wrench to loosen the bolts. **Fig. 67**
5. Push or pull on the front of the seat, evenly on both sides, until the seat reaches the desired depth. **Fig. 67**
6. Tighten the adjustment bolts (**Fig. 67**) and any additional accessories loosened.

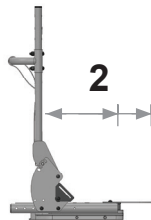


**Fig. 67**

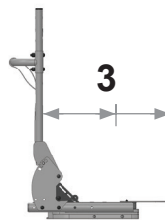
**⚠ WARNING:** Do not place user on the chair while seat adjustments knobs are loosened. Make sure the knobs are fully tightened before placing the user on the chair.



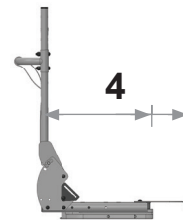
Most Forward Position  
**Fig. 68**



One Hole Position Rearward  
**Fig. 69**



Two Holes Position Rearward  
**Fig. 70**



Three Holes Position Rearward  
**Fig. 71**

Position Options	1	2	3	4
Trekker 12 Seat	7.5"-9.5"	9.5"-11.5"	11.5"-13.5"	NA
Trekker 14 Seat	9.5"-11.5"	11.5"-13.5"	13.5"-15.5"	14.5"-16.5"

**Fig. 72**



- ⚠ WARNING:** When using the Trekker 12 or Trekker 14 back canes seating module in reverse configuration and set to seat depth position 1, the recline adjustment of 80° combined with -10° anterior tilt may cause the chair to tip. To reduce the possibility of tipping, add anti-tips to the chair.

## Seat Width Adjustment

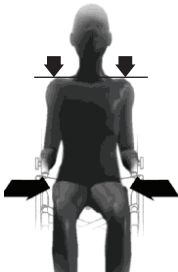


Fig. 73

While user is seated on a flat surface, measure from hip to hip. The user's hip width should not be greater than the width of the seat cushion. **Fig. 73**

## Hip Guides w/Armrest

### Width Adjustment:

1. Remove Seat Cushion. **Fig. 74**
2. Loosen the four adjustment bolts with 5/32" allen wrench. **Fig. 75**
3. Adjust to the desired width and retighten the hardware. **Fig. 76**



Fig. 74

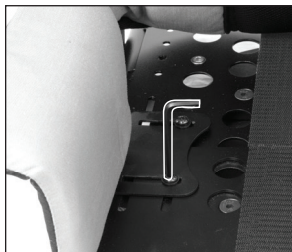


Fig. 75

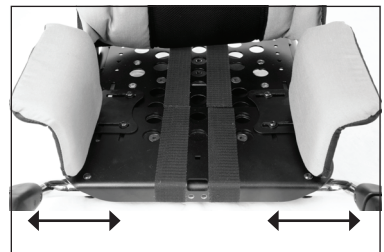


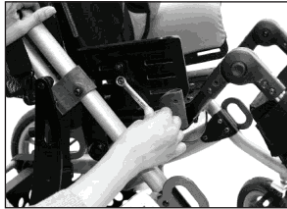
Fig. 76

**Depth Adjustment:**

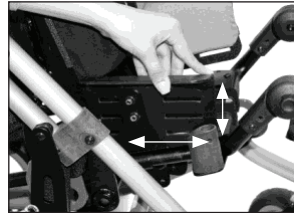
1. Remove hip guide cover. **Fig. 77**
2. Use 7/16" wrench to loosen hardware. **Fig.76**
3. Using the provided slot, adjust to the desired depth and retighten. **Fig. 79**



**Fig. 77**



**Fig. 78**



**Fig. 79**

**Height Adjustment:**

1. Remove hip guide cover. **Fig. 77**
2. Using 7/16" wrench remove the bolt and nut. **Fig. 78**
3. Adjust to the desired height using the two designated slots and install hardware. **Fig. 79**

**To Install:**

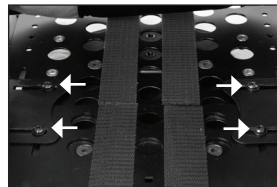
1. Remove Seat Cushion. **Fig. 80**
2. Remove the two adjustment bolts on top of the seat pan with 5/32" allen wrench **Fig. 81**
3. Install the hip guide and re-install adjustment bolts into designated holes on seat pan.
4. Tighten the adjustment bolts. **Fig. 82**
5. Place cushion over the hip guide. **Fig. 83**
6. Repeat on opposite side.

**To Remove:**

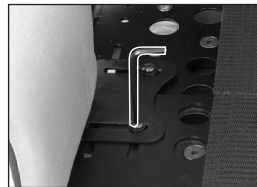
1. Remove Seat Cushion. **Fig. 80**
2. Remove the two adjustment bolts on top of the seat pan (**Fig. 81**), with 5/32" allen wrench. **Fig. 82**
3. Remove hip guide and reinstall hardware to secure seat pan. **Fig. 83**
4. Repeat on opposite side.



**Fig. 80**



**Fig. 81**



**Fig. 82**



**Fig. 83**

## Laterals

### To Adjust:

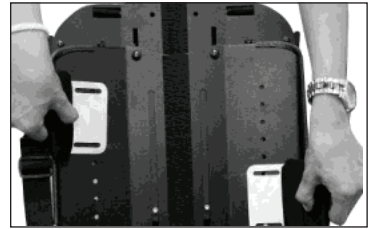
1. Remove Back Cushion. **Fig. 84**
2. Using 5/32" Allen wrench and 7/16" wrench, loosen the hardware and adjust hardware as needed to provide user with adequate trunk support. **Fig. 85**
3. Retighten the hardware.



**Fig. 84**



**Fig. 85**



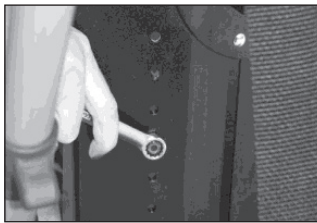
**Fig. 86**

### To Install:

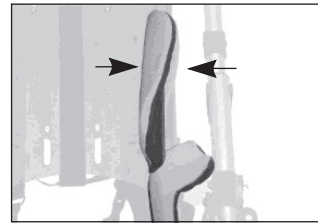
1. Remove Back Cushion. **Fig. 85**
2. Remove bolt and washer from height adjustable solid back. **Fig. 86**
3. Attach lateral support and insert bolt for desired height hole on height adjustable solid back. **Fig. 87**
4. Using 5/32" Allen wrench and 7/16" wrench, tighten the hardware. **Fig. 88**



**Fig. 87**



**Fig. 88**



**Fig. 89**

**Note:** To adjust lateral height down to minimum range, remove the cable bracket using a 5/32" Allen wrench and 7/16" wrench and reattach with laterals, without washer.

**Note:** DO NOT USE center slot.

### To Remove:

1. Remove Back Cushion. **Fig. 87**
2. Use 7/16" wrench to loosen hardware. **Fig. 88**
3. Loosen bolt and washer from height adjustable solid back. **Fig. 89**
4. Repeat on opposite side.

## Tilt-In-Space Adjustment

The Trekker Chair is equipped with a tilt-in-space mechanism. The tilt-in-space range in the Trekker is  $-10^{\circ}$  anterior to  $45^{\circ}$  posterior. **Fig. 90**

### To Adjust the Tilt Angle:

1. With your right hand, hold onto the handle, on the back on the seat to support the weight of the user. **Fig. 91**
2. With your left hand, squeeze the tilt adjustment lever on the frame.
3. Move the user to the desired tilt angle while holding the handle and the tilt adjustment lever. **Fig. 91**
4. Release the lever to engage the tilt adjustment lever lock.



**Fig. 90**



**Fig.91**

**⚠ WARNING:** When activating the tilt, gradually squeeze the lever to allow the care giver to support the weight.

**⚠ WARNING:** When using the Trekker 12 or Trekker 14 back canes seating module in reverse configuration and set to seat depth position 1, the recline adjustment of  $80^{\circ}$  combined with  $-10^{\circ}$  anterior tilt may cause the chair to tip. To reduce the possibility of tipping, add anti-tips to the chair.

**⚠ WARNING:** In preparation to operate the tilt:

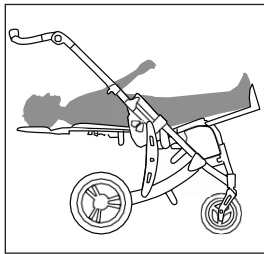
- Always verify that the arms and legs of the user are stable and within the seat base.
- Always verify that the user's legs are stable and on the foot support.
- Never place hands, feet or foreign objects into the tilt mechanism area.
- Never add chair accessories that are not specifically designed for the Trekker Chair, as they may interfere with the tilt mechanism.
- Never allow the user's head to tilt/recline beyond the horizontal plane to the floor.
- Never operate the tilt mechanism without having a firm hold of the seating module and be aware that a change in angle can create a sudden weight shift.
- Always verify tilt stopper is in the correct position.

## Recline Adjustment

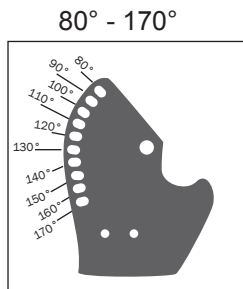
The Trekker comes standard with Back Angle Adjustment of 80° - 110° in increments of 10°.

### Optional Feature:

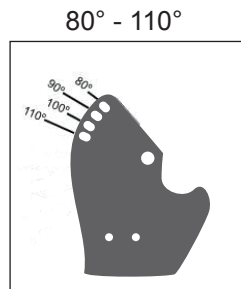
1. The Trekker has an additional recline option to extend the back angle adjustment to full recline range of 80° to 170° of recline adjustment.
2. Make sure wheel lock is engaged.
3. If user is in the chair, move the user's back forward slowly and carefully to shift user's weight.
4. Grab the center of the recline strap. **Fig. 91**
5. With your free hand on the top of the back, and while holding the recline cord, adjust the back to the desired recline angle and release the recline strap.
6. Confirm that the recline lock pins are fully engaged on both sides. **Fig. 95**
7. Replace user to relaxed position. Release wheel lock.



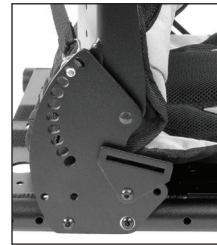
**Fig. 92**



**Fig. 93**  
Recline Degrees  
(Optional)



**Fig. 94**  
Recline Degrees  
(Standard)



**Fig. 95**



**WARNING:** Engage wheel lock prior to adjusting recline angle.



**WARNING:** Check to confirm that recline lock pins are fully engaged prior to use. **Fig. 95**



**WARNING:** Keep fingers free of recline mechanism.



**WARNING:** Never allow the user's head to tilt/recline beyond the horizontal plane to the floor. **Fig. 90**

**Note:** Recline angle can also be referred to as seat-to-back angle or back angle adjustment.

## Pelvic Positioning Belts

---

**⚠ WARNING:** Positioning belts should never be used as a safety restraint device in a motor vehicle when transporting chair with occupant. An additional WC-4-19 or ISO 7176-19 compliant automotive type seat belt is required when the chair is used in transport vehicles. Make sure the occupant does not slide down in the wheelchair seat.

1. The belts must be snug, but not too tight. You should be able to slide your open hand, flat between the belt and the occupant.
2. NEVER use positioning belts as a user restraint, or on an occupant who is comatose or agitated.
3. Failure to heed these warnings may cause serious injury.

## Two-Point Positioning Belt

---

### To Buckle:

Snap together the two straps at the buckle. **Fig. 96**

### To Release:

Press on each side to release buckle and pull away from each other.



**Fig. 96**

## Three-Point Positioning Belt

---

### To Buckle:

Slip the metal clasp on the belt strap into the strap buckle. **Fig. 97**

### To Release:

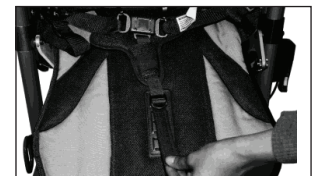
Press the gray button on the buckle and pull out the clasp.



**Fig. 97**

### Optional Feature:

The strap is connected with the gray quick-release buckle. It can be adjusted by threading the strap through desired slot on the seat cushion. **Fig. 98**



**Fig. 98**

## H-Harness with Padded Covers

### Optional Feature:

Prior to adjusting the H-Harness, please make sure to adjust the back adjustment height, as shown in (Fig. 99), so that the top of the back panel is at the height of the user's shoulder.

1. To adjust the H-Harness, insert the H-Harness straps through the H-Harness attaching slots.  
**Fig. 99**
2. After feeding through the slot, insert the strap through the buckle by lifting the tab, feeding through the buckle and lowering the buckle tab to secure the strap as show in (Fig. 100) and pull to the desired tightness.

**NOTE:** Proper support adjustments can be made by tightening or loosening the straps on the harness.

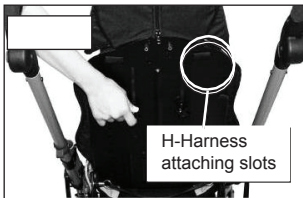


Fig. 99



Fig. 100



Fig. 101

## Extended Strap Vest (Butterfly Harness)

1. Stand behind user and pull finger loops to adjust top straps.
2. Pull finger loops to adjust bottom.



Fig. 102

## Footplate Height Adjustment

Trekker foot support is height adjustable.

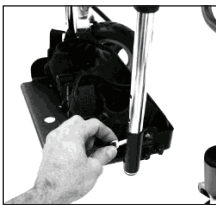
To determine the correct seat-to foot support Height, measure from the back of the knee to the bottom of the heel.

### To adjust the height:

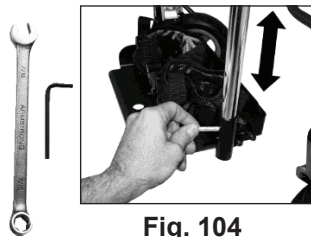
1. Pull out safety detent pin as shown in **Fig. 103** and remove. Repeat on the other side while holding foot support with one hand.
2. Adjust foot support height as needed to accommodate user's lower leg measurement. **Fig. 104**
3. Install safety detent pins on both sides making sure the detent pins go all the way through.



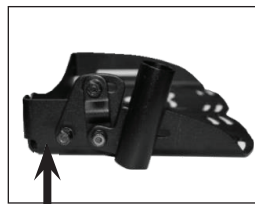
**Fig. 105**



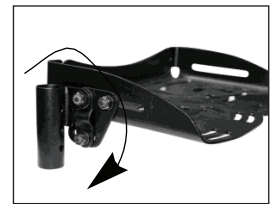
**Fig. 103**



**Fig. 104**



**Fig. 105**



**Fig. 106**

**⚠ WARNING:** Some foot support settings can cause the foot support to interfere with the front casters.

### For additional range:

1. Using a 5/32" Allen wrench and a 7/16" wrench to remove the two screws connecting bracket from footplate. **Fig. 105**
2. Rotate connecting bracket 180° and reattach through the open slot with a 5/32" Allen wrench and a 7/16" wrench. **Fig. 106**
3. Repeat steps 1-2 on opposite side.

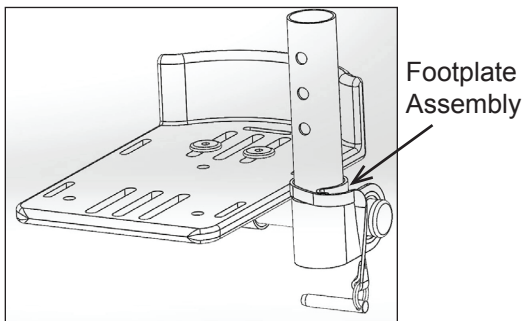


## Individual Footplates

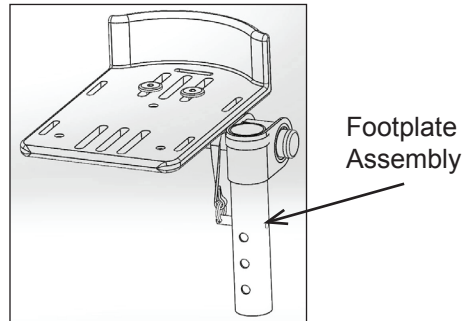
To adjust minimum seat to footplate height:

1. Flip and swap the individual footplate assemblies. **Fig. 107 & 108**
2. Use a 5/32" Allen wrench to loosen the nuts and bolts from each footplate.
3. Slide the footplate out and adjust the lock pin to the upper locking position.
4. Reattach the footplates at desired angle.
5. Retighten hardware.
6. Adjust to desired height.

**NOTE:** The lock pin must be in locking position.



**Fig. 107** Standard Footplate



**Fig. 108** Flipped Footplate



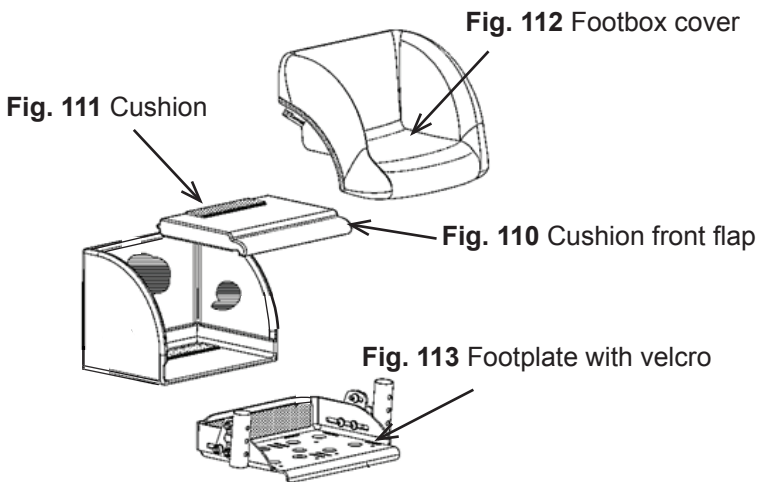
**Fig. 109** Individual Angle Adjustable Footplates

## Footbox Cover

---

### To install footbox cover to one-piece footplate:

1. Attach the footbox cushion to the footbox base using Velcro. **Fig. 110**  
**Note:** Make sure the front flap of the box cushion is facing forward when attaching the cushion.
2. Secure the cushion to the footbox by wrapping the front flap of the cushion underneath the footbox. **Fig. 111**
3. After securing the cushion to the footbox attach the cover by wrapping it over the footbox base. **Fig. 112**
4. Attach the footbox cover to the footplate using the provided Velcro strip. **Fig. 113**



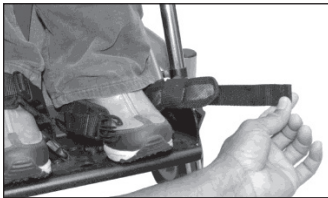
## Foot Positioners

Adjustable foot positioners hold feet in position on the foot support. The foot positioners may be criss-crossed over the top of the foot to secure the entire foot.



**Fig. 114**

The foot positioners can also be converted to an ankle strap. To convert into an ankle strap, remove left buckle and secure the loose end of the strap. Wrap the right strap around the ankle and fasten the buckle.



**Fig. 115**



**Fig. 116**

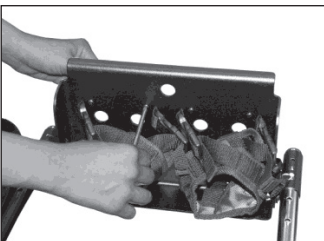


**Fig. 117**

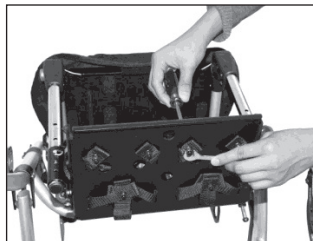


**Fig. 118**

To attach the positioners, thread the strap through top of footplate, and bolt to underside of footplate, using a 3/8" wrench and Phillips screwdriver.



**Fig. 119**



**Fig. 120**

## Wheels Specifications

The Trekker comes standard with 7.5" x 2" front solid tires and 11.5" x 2.5" rear solid tires. You can upgrade, replace or re-order Trekker tires at any time. You have the option of upgrading to pneumatic tires or re-ordering replacement standard solid tires. When ordering upgraded or replacement tires, please have the following information available:

- Chair model and size (ex: TR12)
- Wheel size (ex: 7.5" x 2")

**⚠ WARNING:** Do not use the chair unless it has proper tire pressure. (Front 36 psi/ Rear 30 psi, 248kPa/200kPa, 2.5BAR/2.0BAR) Do not over inflate the tires. Failure to follow these instructions may cause the tire to explode and cause harm.



**Fig. 121**



**Fig. 122**

Pneumatic Tire Sizes (option)  
7.5" x 2" (front)  
11.5" x 2.5" (rear)

## Removal & Installation of Rear Wheels

**To remove the wheels:**

1. Release the wheel lock bar.
2. Press down on the clip (**Fig. 123**) near the center of the wheel hub.
3. Pull the wheel outward to remove it from the chair. **Fig. 124**

**⚠ WARNING:** Do not remove silver clip.



**Fig. 123**



**Fig. 124**



**Fig. 125**

**To install the wheels:**

1. Disengage wheel lock by pulling wheel lock bar upward with toe.
2. Hold the axle and wheel. Align the wheel hub with the axle.
3. Slide the wheel as far as possible onto the axle until you hear a "click".
4. Ensure the wheel has secured on the axle by pulling outward on the wheel without pressing clip. **Fig. 125**
5. Ensure that the wheel is secured on the axle by pulling outward on the wheel without pressing clip. Wheel will not come off if clip is properly engaged.

# Accessories

## Medical Necessity Storage Basket

### Optional Feature:

The Medical Necessity Storage Basket is made of texteline mesh and durable plastic and suspends from the chair frame by Velcro straps. The Medical Necessity Storage Basket can hold a weight capacity of up to 50lbs.

**Note:** Convaid logo must be facing the right side of chair when installing.



Fig. 126

**! WARNING:** Remove medical necessity storage basket during transport in a motor vehicle.

**! WARNING:** To clear obstacles such as curbs and steps, tilt the chair onto the rear wheels. When going down a curb, approach the curb backwards. Lower the rear wheels down the curb and continue backwards, taking the weight off the front wheels so they can be gently lowered. When going up a curb or step, face forward and tilt the chair back to lift the front wheels over the curb. Move forward and lift the rear wheels over the curb. The Trekker curb clearance is 7.5" (190mm); the curb clearance with the storage basket is 2.2" (560mm).

## Ventilator/Suction/Hard Tray



Fig. 127

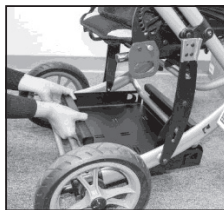


Fig. 128

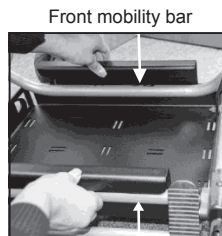


Fig. 129 Back mobility bar

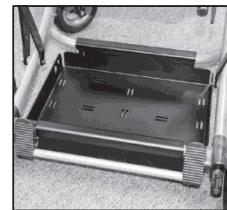


Fig. 130

1. Slide tray through bottom chair frame  
Fig. 127, Fig. 128
2. Attach the tray by hooking to front mobility bar.  
Fig. 129
3. Attach the back of the tray by hooking it to the rear bottom mobility bar. Fig. 130

## Head Support

### Attaching Headrest:

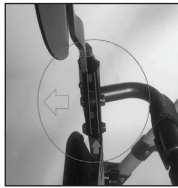
1. Remove headrest cover by unzipping the cover on the back side. **Fig. 131 & 132**
2. Using a 5/32" Allen wrench and 7/16" wrench, secure the two provided mounting Allen screws on the top center of the upper back plate. **Fig. 133**
3. Adequately tighten hardware.

### Adjusting the Headrest:

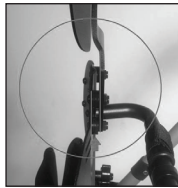
1. Remove headrest cover by unzipping the cover. **Fig. 131 & 132**
2. Using a 5/32" Allen wrench and 7/16" wrench, loosen the two provided mounting Allen screws. **Fig. 133**
3. To adjust the height, once the mounting hardware has been loosened, move the headrest up or down as needed. **Fig. 134**
4. Secure the mounting hardware adequately and replace cover.



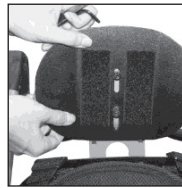
**Fig. 131**



**Fig. 132**



**Fig. 133**



**Fig. 134**

**Note:** Always mount headrest hardware to the front of the seating module.

### Adjustable Headwing Headrest Instructions

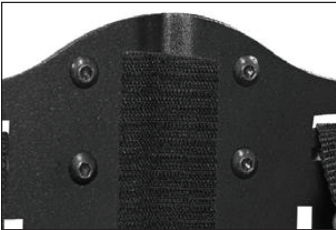
1. Unzip the cover from the back of the headrest.
2. Slightly move the cover to reveal the silver locking screw on the plastic headrest plate.
3. Note that the locking screw of the right hand side is on the top portion of the pivot hinge.
4. The locking screw of the left hand side is on the bottom portion of the pivot hinge.
5. Using a 5/32" Allen wrench to loosen the screw.
6. Rotate the adjustable wings of the headrest to the desired location.
7. Use a 5/32" Allen wrench to tighten screw.
8. Repeat steps 4 to 6 for the other side.



**Fig. 135**

# Universal Bracket

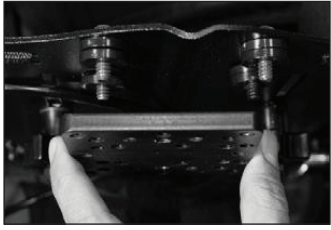
1. Insert screw into one of the four holes on the upper portion of the back pan of the universal plate. **Fig. 136**
2. Orient the universal plate to desired position.
3. Partially thread the screw onto the plate but do not tighten.
4. Repeat steps 1 to 3 for the other three attachment screws.
5. Using a 5/32" Allen wrench, tighten all four attachment screws.



**Fig. 136**

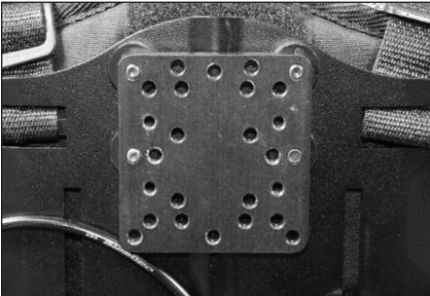


**Fig. 137**

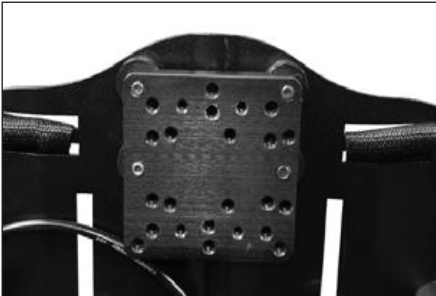


**Fig. 138**

**90° rotated**



**Fig. 139**



**Fig. 140**

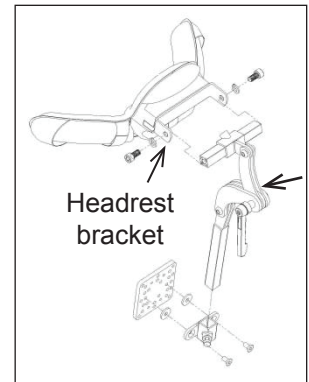
## R82 Anatomic Headrest

### Installing Anatomic Headrest to Turtle Bar System

1. Align the anatomic headrest bracket with turtle bar system.  
**Fig. 141**
2. Use 6mm Allen wrench to tighten the connecting hardware.  
**Fig. 142**

**Note:** Do not remove the preinstalled head rest bracket. **Fig. 140**

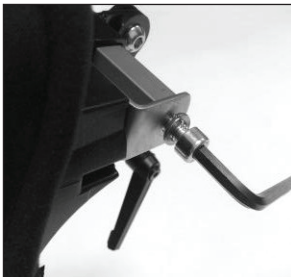
**Note:** Universal bracket must be oriented to the position as shown in **Fig. 143**



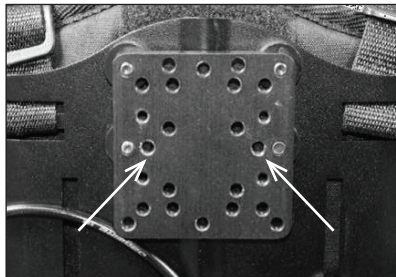
**Fig. 141**

### Installing the Headrest Mount onto the Universal Bracket

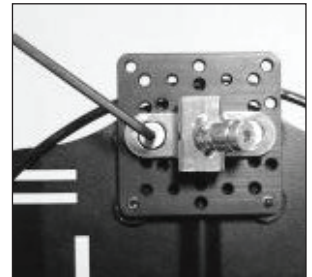
1. Locate the center securement hole located on the universal bracket. **Fig. 143**
2. Use 4mm Allen wrench to tighten the connecting hardware. **Fig. 144**



**Fig. 142**



**Fig. 143**



**Fig. 144**

### Installing the Headrest Mount onto the Universal Bracket

1. Install the system into the bracket. **Fig. 143**
2. Adjust to desired height and secure the system by tightening the securement bolt with 5mm Allen wrench.



**WARNING:** Do not set height beyond the maximum indicated line.



**Fig. 143**



### To Adjust the Turtle Bar System

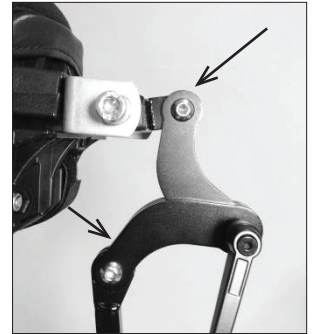
1. Use 5mm Allen wrench to loosen the bolts and loosen the lever. **Fig. 146**
2. Adjust to desired depth and height then retighten the bolts and lever.

### To Remove Cover

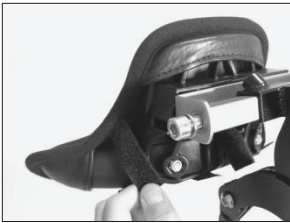
Detach the three Velcro strips and remove cover. **Fig. 147**

### To Install Cover

Slide cover onto the headrest unit and secure with Velcro strips. **Fig. 148**



**Fig. 146**



**Fig. 147**



**Fig. 148**

## Canopy Bracket Installation

### Aftermarket Kit Includes: Fig. 149

- 2 Canopy brackets with Hardware
- 1 5/32" Allen Wrench
- 1 7/16" & 3/8" Wrench



Fig. 149

### To Install the Canopy Bracket:

1. Install the canopy bracket at the location as shown. **Fig. 150, 151, 152**
2. Tighten hardware with 5/32" Allen wrench and 7/16" wrench. **Fig. 153, 154, 155**
3. Repeat for opposite side.

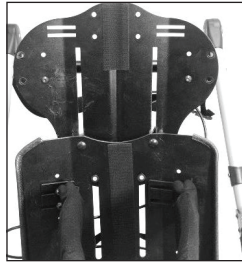


Fig. 150

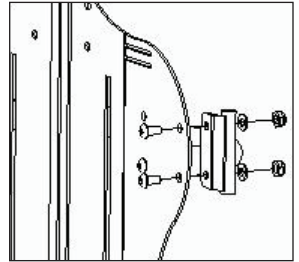


Fig. 151

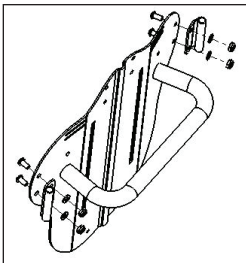


Fig. 152

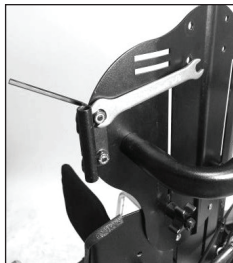


Fig. 153



Fig. 154



Fig. 155

## Canopy Attachment

1. Rotate push handle down. **Fig. 156 & 157,**
2. Insert canopy rod into brackets located on the sides of the back of the seating module.
3. Rotate handle to desired position. **Fig. 158**

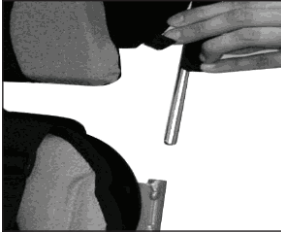


Fig. 156

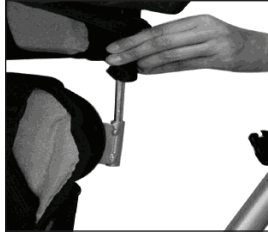


Fig. 157

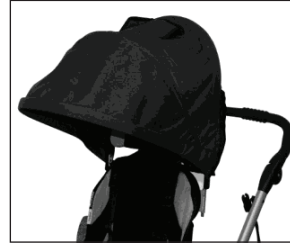


Fig. 158

## Oxygen Tank Holder

### How to Hang the Oxygen Tank Holder:

1. Align top and bottom slots of oxygen tank holder with top and bottom bushings on left hand side of chair. **Fig. 159**
2. Slide the tank holder down on bushings to lock oxygen tank holder into place. **Fig. 160**



Fig. 159



Fig. 160



Fig. 161



Fig. 162

### How to Secure Oxygen Tank:

1. Place tank onto the bottom lip of the oxygen tank holder. **Fig. 161**
2. Secure with the upper strap by buckling tight.(repeat bottom buckle) **Fig. 162**
3. Confirm the strap is secure.

## I.V. Pole

The folding I.V. pole offered on the Trekker accommodates the user when intravenous fluids, medication, or G-tube feeding are necessary. **Fig. 163**

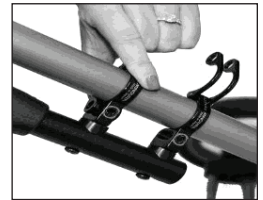
1. The pole easily secures to the Trekker by clamping the pole mount on the side mobility base tubing. **Fig. 164 & 165**. Place bolt into hole of clamp and screw on using 5/32" Allen wrench. **Fig. 166 & 165**

**NOTE:** The I.V. Pole can be removed or folded when not in use. **Fig. 168**

**NOTE:** The I.V. pole can easily be extended in height to accommodate individual needs.



**Fig. 163**



**Fig. 164**

**! WARNING:** I.V. pole should be folded when not in use.



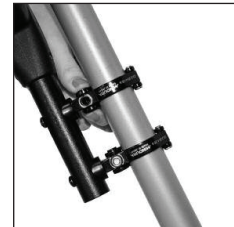
**Fig. 165**



**Fig. 166**



**Fig. 167**



**Fig. 168**

## Elevating Leg Rest (Option)

### To Adjust Height:

1. Place your hand on the grey button located at the knee joint. **Fig. 169**
2. Press the grey button to adjust lower extremity to design angle and release button. **Fig. 170**



**Fig. 169**



**Fig. 170**

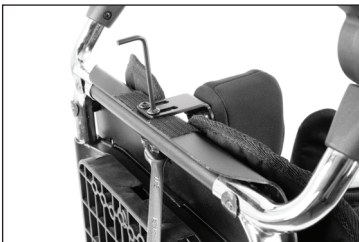
## Medical Knee Abductor (Pommel)

### To Adjust Height:

1. Using 5/32" allen wrench (**Fig. 171**) and 7/16" wrench (**Fig. 172**), loosen the hardware on the seat.
2. Slide the pommel to desired height and retighten hardware. **Fig. 173**
3. Tighten knob. **Fig. 171**

### To Adjust Depth:

1. Remove the seat cushion
2. Using 5/32" allen wrench (**Fig. 171**) and 7/16" wrench (**Fig. 172**), loosen the hardware on the seat.
3. Slide the pommel to the highest position.
4. Using 7/16" wrench, loosen the two adjustment nuts under the pommel.
5. Slide the pommel to desired depth.
6. Retighten the hardware.
7. Install the seat cushion.



**Fig. 171**



**Fig. 172**



**Fig. 173**

## LTV Vent Holder

1. Align male dovetail bracket located on ventilator with female dovetail bracket located on frame. **Fig. 174**
2. Slide down and lock securely into bracket. **Fig. 175**
3. Attached Ventilator. **Fig. 176**



**Fig. 174**



**Fig. 175**

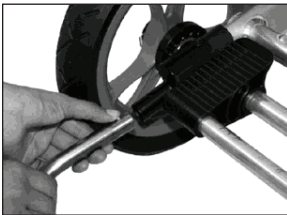


**Fig. 176**

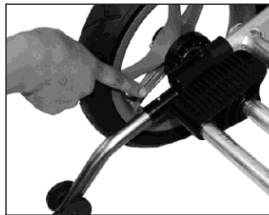
**⚠ WARNING:** Do not use the LTV Holder when using a soft back on the Trekker Back Canes.

## Anti-Tip Tubes

1. To install the anti-tip tube, align the tube with the end of the round mobility base tubing located next to the rear wheel. **Fig. 177**
2. Push the spring button while positioning the anti-tip tube into the round mobility base tubing, and then push until the "release button" pops through the hole located on the anti-tip tube. **Fig. 178**
3. Repeat steps 1 & 2 for opposite side. **Fig. 179**
4. To remove the anti-tip tubes, perform 1-3 steps in reverse order.



**Fig. 177**



**Fig. 178**



**Fig. 179**

---

## Curb Tipper

---

1. To install the curb tipper tube, align the tube angled upwards with the end of the round mobility base tubing located next to the rear wheel. **Fig. 180**
2. Push the spring button while positioning the curb tipper tube into the round mobility base tubing, and then push until the “release button” pops through the hole located on the curb tipper tube. **Fig. 181**



**Fig. 180**



**Fig. 181**

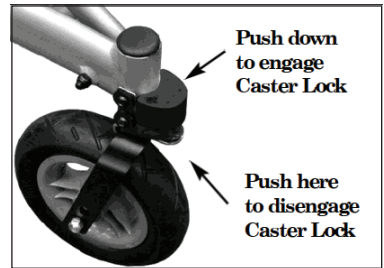
## Caster Locks

**Note:** Casters must be in straight position before engaging.

1. Engage caster lock by pushing the caster lock down.

**Fig. 182**

2. To disengage the caster lock, push the bottom portion of caster lock. **Fig. 182**



**Fig. 182**

## Utility Bag

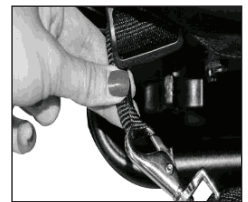
The Utility Bag attaches to the back of the chair, but can be removed and converted to a tote bag. **Fig. 183**

**To attach:**

Hook clasps onto straps. **Fig. 184**



**Fig. 183**



**Fig. 184**

**! WARNING:** Do not overload bag.

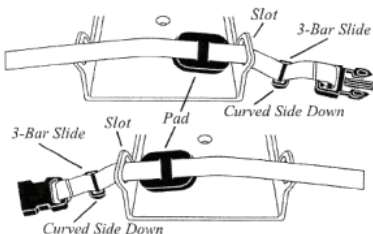
## Shoe Holders

1. Thread the 3-Bar Slide onto the strap with the curved side down. Feed the strap through the molded strap slot. If you have the padded version, thread the Pad onto the strap as shown

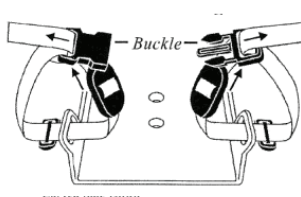
**Fig. 185**

2. Thread the strap end through the Buckle. **Fig. 186**

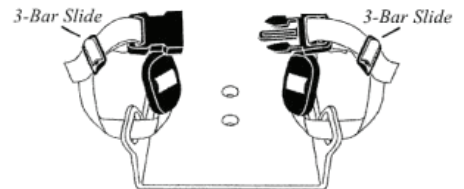
3. Thread the strap end through the 3-Bar Slide. **Fig. 187**



**Fig. 185**



**Fig. 186**



**Fig. 187**



## Upper Extremity Support Tray

The trays are great for feeding and for trunk stabilization.

1. Insert tray into tray mounting bracket. **Fig. 188**
2. Push spring button into mounting tray to secure. **Fig. 189**



**Fig. 188**



**Fig. 189**

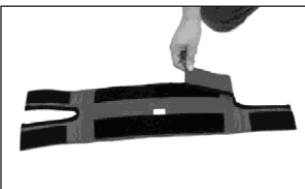
**Note:** Seat depth minimum range is reduced by 1" (25mm) when tray is attached.

**Note:** Minimum seat depth or lowest lateral position may interfere with tray positioning. To avoid interference between lateral and tray, recline seat back.

**Note:** 7" (178mm) hip guides cannot be adjusted in height when combined with tray.

## Calf Panel

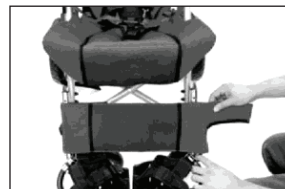
1. Lay Calf Panel flat and unfasten the Velcro straps. **Fig. 190**
2. Attach Velcro straps around Footrest Extension Tube. Position Calf Panel across chair and attach Velcro Straps around opposite Footrest Extension Tube. **Fig. 190 & 192**



**Fig. 190**



**Fig. 191**



**Fig. 192**

## Transit Option

The wheelchair transport model has been crash tested and complies with the requirements of RESNA WC4:2012 section 19 and ISO7176-19:2008.

Dummy weights are:

### Trekker Seating Modules

#### Weight Capacity:

14T.....110lbs/50kg

12T ..... 75lbs/34 kg

Wheelchair user should transfer to the vehicle seat and use the vehicle-manufactured-installed-restraint system whenever it is feasible.

Trekker provides for anchoring of a crashworthy pelvic-belt restraint that conforms to requirements of RESNA WC-4/ ISO 7176, and that can be used in conjunction with a vehicle-anchored shoulder belt with a standard lower anchorage connector for effective crashworthy three-point belt restraint in a motor vehicle.



**Fig. 193**

To reduce possibility of injury, the headrest must always be used with the chair.

The following instructions should be followed to minimize impact in case of crash:

1. During transit, the chair must be forward facing with the seating module in the forward facing position. All non essential accessories should be removed.
2. Use only a tested, proven and compatible 4-point wheelchair tie-down system (WTORS), and a 3-point occupant restraint system in accordance with WC4- 18 or ISO 10542-1.
3. The wheelchair tie-downs must be securely attached to the four transit anchors on the chair. See arrows in above photo for anchor points.
4. The occupant restraints must include a lap and shoulder belt, secured directly to the Trekker mobility base and the vehicle.
5. All floor tie-down straps must be drawn tight in the front and the back to eliminate any forward movement of the chair.
6. Wheelchair restraint manufacturers' instructions must be followed precisely to ensure intended performance.

## Wheelchair Lateral Stability and Belt Restraint Accommodation Rating

Wheelchair Model	Mass (Weight) of Wheelchair (lb./kg)	Test Rating (A,B,C,D)*	Lateral Stability ** (in./mm)
TR-12T	30/13.6	A	0.51/13
TR-14T	31/14	A	0.55/14

\*A = Excellent; B = Good; C = Fair; D = Poor

\*\* "Lateral stability" is the displacement of point P (the center of gravity on the loaded wheelchair) when a platform with the loaded wheelchair is tilted 45° laterally from the horizontal. Higher numbers indicate less stability.

This table refers to tests performed in accordance with WC19 to establish lateral stability during normal travel and the ease of use and proper fit of vehicle-anchored belt restraints. The letter designation reflects the overall rating of the lap and shoulder belt position

## Transportation Mode Instructions

Using the Trekker Chair for Transportation in Motor Vehicles:

The Transit Model Trekker is for transporting users in motor vehicles when it is equipped with the OPTIONAL Transit feature and used in accordance with these instructions. The chair must be secured in a forward-facing position with Wheelchair Tiedown and Occupant Restraint Systems (WTORS), which meets the requirements of WC-4: section 18 or ISO 10542-2 Recommended Practice—Wheelchair Tiedown and Occupant Restraint Systems For Use in Motor Vehicles.

### IMPORTANT INFORMATION:

This transit option conforms to and has been dynamically tested in accordance with RESNA WC- 4:2012 Section 19 (WC19) and ISO 7176-19:2008



**WARNING:** The wheelchair should be used as indicated in the User's Guide instructions accompanying the wheelchair. Failure to do so increases the likelihood of serious injury in a vehicle crash.












**WARNING:** Do not over tighten this may cause damage to the mobility base.



**WARNING:** Straps are for positioning only and are not to be used as a vehicle restraint.



**WARNING:** Pelvic and belt restraint should be use to limit occupant movement.

-  **WARNING:** Trekker was dynamically crash tested in a forward-facing configuration using an appropriately sized crash-test dummy restrained by both upper-torso (shoulder) and lower-torso (lap) belts. To reduce the possibility of head and chest injuries resulting from contact with vehicle components, you must use both upper and lower torso belts.
-  **WARNING:** The belt restraints must remain in position on skeletal portions of the body and not place undue stress on the abdomen.
-  **WARNING:** Both pelvic and torso restraint belts must be used while traveling aboard a motor vehicle.
-  **WARNING:** When riding aboard a motor vehicle, it is preferred that the wheelchair user transfer into the vehicle's manufacturer's seat and use a federally approved, crash-tested seat.
-  **WARNING:** Keep seatbelt release button away from other wheelchair components to avoid releasing during crash
-  **WARNING:** Whenever possible, auxiliary wheelchair equipment should be removed from the wheelchair and secured in the vehicle during transit so that it does not break free and cause injury to vehicle occupants during a crash.
-  **WARNING:** Do not alter or substitute any part or component of the wheelchair, wheelchair mobility base or wheelchair seating module.
-  **WARNING:** Do not attach tie downs anywhere except designated tie down locations.
-  **WARNING:** Do not use the chair if it has been involved in a crash. In the event that your Trekker is involved in a crash, please contact the Convaid Service Dealer or Convaid Customer Service Representative in order to arrange an evaluation of your Trekker.

**WARNING:** During transit, chair must be forward facing with the seating module in the forward facing position on the mobility base. All non-essential accessories should be removed.

**WARNING:** Adequate clear zones are required for occupants restrained by both upper - and lower-torso belt restraints. See **Figs. 194 & 195**.

## RECOMMENDED CLEAR ZONES IN VEHICLE

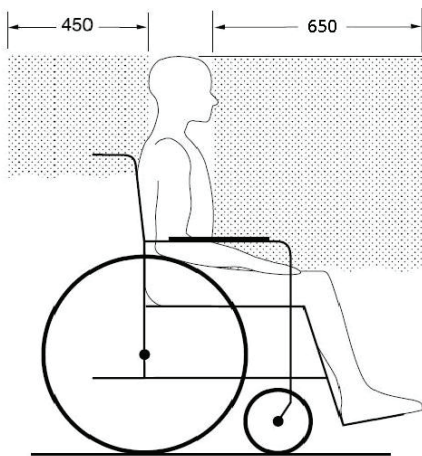


Fig. 194

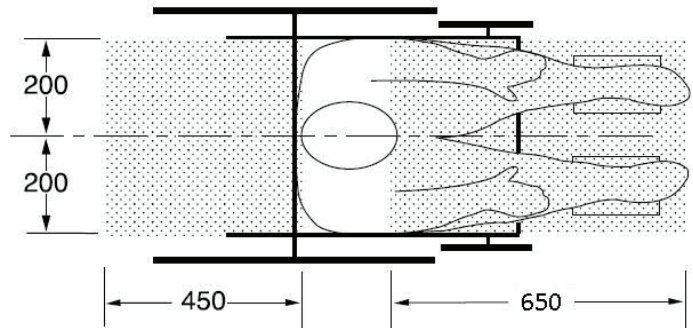


Fig. 195

The rear clear zone is measured from the rearmost point on an occupant's head. The front clear zone is measured from the frontmost point on an occupant's head.

Dimensions are shown in millimeters.

## Providing Clear Space & Padding

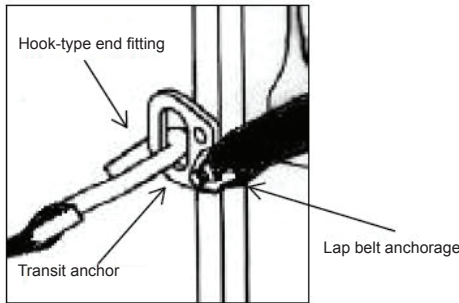
Position the wheelchair aboard the motor vehicle to ensure sufficient clear space in front of, and behind, the occupant. (See **Figs. 194 & 195**)

**WARNING:** If there are any hard or sharp objects or components near the wheelchair, such as components of lifts or fold-up seats, they must be covered with heavy-duty energy-absorbing padding to ensure the safety of the wheelchair occupant and other passengers.

## PROPER USE OF EQUIPMENT

### Securing the Wheelchair

Attach tiedown straps to securement points (black brackets) located on the wheelchair's legs in accordance with the WTORS manufacturer's instructions. Securement points are identified by the symbol in **Fig. 198**, and their location on the wheelchair illustrated in **Fig. 197**



**Fig. 196**



**Fig. 197**

When securing the occupied wheelchair, it is important that the WTORS anchor points on the floor and wall of the motor vehicle are positioned properly according to the WTORS manufacturer's instructions. The wheelchair must be positioned facing forward inside the vehicle. Position the wheelchair between the front and rear anchor points ( **Fig 200** ), allowing for the correct angle of adjustment of the tiedown straps, as illustrated in **Fig. 199**



**Fig. 198**

Your Convaid transit wheelchair can be easily secured by the four strap-type tiedowns by attaching the hook end fittings of the tiedown straps to the four transit anchors located on the four tubular legs of the wheelchair or by threading tiedown straps through the openings in the transit anchors.

The floor anchor points and wheelchair should be located:

- so that the tiedown straps follow a straight, clear path from the wheelchair transit anchors to the floor anchor points and
- so that the front straps are angled outward from the sides of the wheelchair and
- so that the rear straps are anchored straight back from the wheelchair transit anchors

Once all four tiedown straps are attached to the wheelchair:

- inspect all tiedown straps for signs of wear to the webbing and replace any straps that are worn and
- tighten the straps to remove any excess slack and provide tension between the front and rear tiedown strap

PREFERRED ANGLES OF FRONT AND REAR TIEDOWN STRAPS (Fig. 199) AND PREFERRED LOCATIONS OF FLOOR ANCHOR POINTS (Fig. 200).

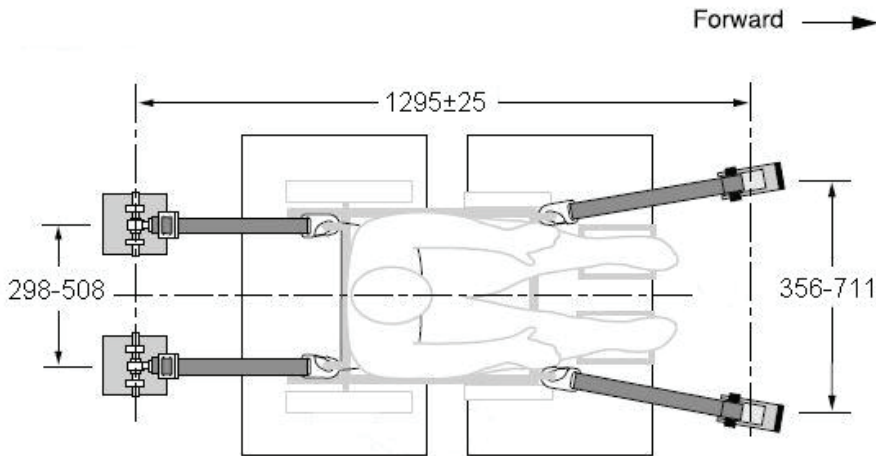


Fig. 200

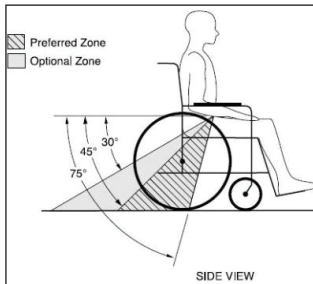


Fig. 199

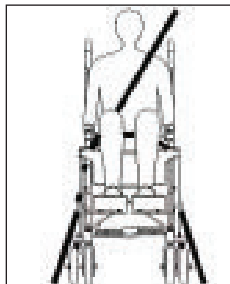


Fig. 201

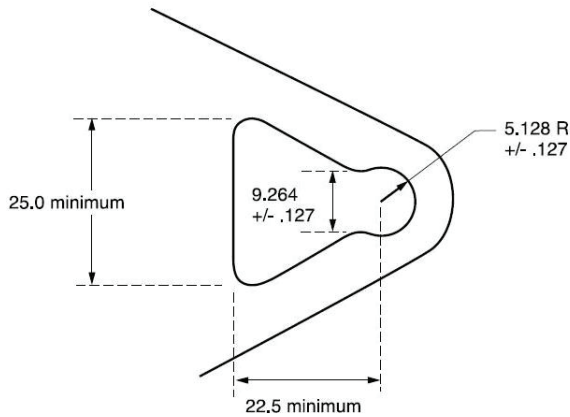


Fig. 202

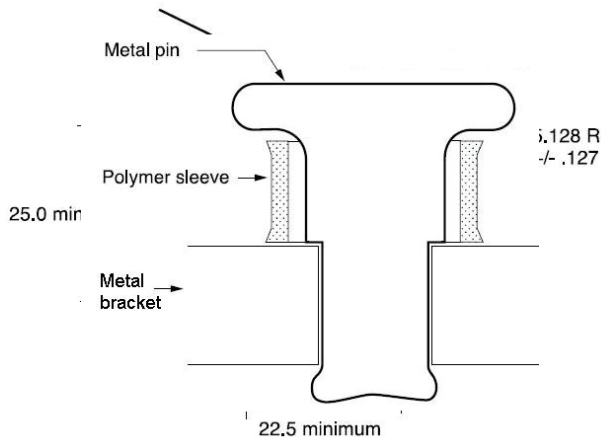
Fig. 201: FRONT TIEDOWN STRAPS ANGLED AWAY FROM SIDES OF WHEELCHAIR.

Fig. 202: CORRECT POSITIONS OF SHOULDER AND LAP BELT RESTRAINTS AND WHEELCHAIR TIEDOWNS.

STANDARD METAL CLIP (**Fig. 203**) AT LOWER END OF SHOULDER BELT AND AT END OF OPTIONAL WHEELCHAIR-ANCHORED LAP BELT USED TO CONNECT TO PIN/BUSHING (**Fig. 204**) ON LAP BELT OR ON WHEELCHAIR TRANSIT ANCHORS.



**Fig. 203**



**Fig. 204**



---

## Restraining the Wheelchair Occupant

---

Your Convaid transit wheelchair was dynamically crash tested in a forward-facing configuration using an appropriately sized crash-test dummy restrained by both upper- torso (shoulder) and lower-torso (lap) belts. To reduce the possibility of head and chest injuries resulting from contact with vehicle components, you must use both upper and lower torso belts. **(See Figs. 201 & 200)**

Your Convaid transit wheelchair provides for the use of an optional wheelchair-anchored lap belt. The optional belt, which has been dynamically tested in accordance with Annex A of WC19, may be ordered from Convaid at a nominal additional cost. To attach the lap belt to the wheelchair, secure the metal clips at the ends of the lap belt **(Fig. 203)** to the pin/bushing connectors located on the wheelchair's rear transit anchors. **(Fig. 204)**

Before loading the wheelchair onto the vehicle lift, fasten the lap belt over the wheelchair user's pelvis. The wheelchair user should wear the optional lap belt as low over the pelvis and as snugly as possible without compromising comfort. The vehicle-anchored shoulder belt may then be clipped to the pin/bushing connector located on the lap belt near where it attaches to the chair. When not in use, the optional lap belt may be looped underneath the seat, buckled, and tightened.

If the wheelchair is purchased without the optional lap belt or if the wheelchair user elects not to use the belt, a vehicle-anchored lap and shoulder belt must be used. As with the wheelchair-anchored lap belt, it is very important to position the vehicle-anchored lap belt low over the pelvis so that the angle of the lap belt is within the preferred zone of 45° to 75° to the horizontal or the optional zone of 30° to 45° to the horizontal, as shown in **Fig. 200**.

Note: Steeper side view pelvic-belt angles are especially important if the pelvic belt is intended to be used for postural support in addition to occupant restraint in a frontal crash. Steeper angles will reduce the tendency for a vertical gap to develop between the user and the belt due to compliance of seat cushions and belt movement, thereby reducing the tendency for the user to slip under the belt for the belt to ride up on the soft abdomen during normal use.

Note: Steeper belt angles also reduce the tendency for upper-torso belts to pull the pelvic belt onto the abdomen during frontal impact loading.

Be sure that the shoulder belt crosses the chest and the middle of one shoulder and that belt restraints are not held a way from the body by wheelchair components or parts, such as arm rests or wheelchair legs. (See Fig. 205)

Thread the lap belt under the mobility base tubes located directly under the user's elbows and pull the belt snug against the pelvis. Ensure that belt webbing is not twisted as this may compromise safety. It is best for Trekker to be transported with the seat in a relatively upright orientation. However, if the seat must remain in a tilted position for medical reasons, the seat back should not be reclined more than 30° from the vertical. If it is necessary to recline the seat more than 30°, move the shoulder belt anchor point rearward on the vehicle wall so that the shoulder belt remains in contact with the wheelchair user's shoulder and chest.



Fig. 205

## Using Postural Belts & Supports

Positioning accessories such as pelvic positioning belts, anterior trunk supports, and lateral trunk supports may be used while in transit, but are not designed to provide restraint during a crash. Postural supports and belts should therefore not be relied on for restraint in a vehicle crash and should be used only in conjunction with lap and shoulder belts that have been designed for restraint in a motor vehicle and crash tested in accordance with SAE J2249/WC-4, ANSI/RESNA WC19 and/or ISO 10542-1.

## Trays & Other Wheelchair Components

---

To reduce the risk of potential injury to the wheelchair user or other occupants in a motor vehicle crash, wheelchair-mounted accessories, such as trays and respiratory equipment, must be removed and secured separately during transit. Use tether straps or other strong attachment hardware to prevent items from breaking loose and causing injury during a crash. If it is absolutely necessary to keep a tray on the wheelchair during transit, energy-absorbing padding must be placed between the edge of the tray and the wheelchair user or serious injury may result during a crash.

## WTORS Manufacturers

---

Convaid is a wheelchair manufacturer and does not offer wheelchair tiedown and occupant restraint systems (WTORS). However, products that comply with current WTORS standards can be obtained from the following companies that specialize in crash-tested WTORS:

Q'Straint, Sure-Lok, Unwin and Ortho Safe specialize in crash-tested tie-down systems and are in no way associated with Convaid.

Ortho Safe Systems  
P.O. Box 8865  
Trenton, NJ 08650 U.S.A  
(609) 587-9444

Q Straint  
5553 Ravenswood Rd.  
#110 Ft. Lauderdale, FL  
33312 U.S.A  
(954) 986-9987

Sure-Lok  
2501 Baglyos Circle  
Bethlehem, PA 18020  
U.S.A (866) 787-3565

Unwin Safety Systems  
Unwin House  
The Horseshoe Coat Road,  
Martock, TA12, 6EY U.K.  
(44) (01935) 827740

# Important Information

## Maintenance, Operating & Safety Instructions

- READ ALL INSTRUCTIONS BEFORE USING THE PRODUCT
- ALWAYS FOLLOW THESE SAFETY INSTRUCTIONS
- SAVE SAFETY INSTRUCTIONS FOR FUTURE REFERENCE

**WARNING**



**Fig. 206**

- For user safety, the seat belt should be fasten at all times.
- Do not leave user unattended.
- Do not strap user too tight.
- Always apply wheel locks before letting go of the chair.
- Remove storage basket during transport, except when medically necessary.
- If front edge of seat is at or forward of the point where tires touch the floor, avoid using front of seat tubes for support during entry or exit from chair to prevent tipping.
- Avoid using foot supports for weight support during exit or entry of the chair.

### Waste Disposal

The shipping carton should be kept for possible return to the manufacturer/service facility for repair or maintenance. Other paper packaging waste should be set aside for recycling. For disposition of replaced parts or the complete chair, the materials should be separated into: plastic, rubber, steel, aluminum, etc., and set aside for recycling.

### Intended Use

Convaid's Trekker is a lightweight non-rigid high strength aluminum wheelchair with a tilt and recline mobility system for everyday indoor and outdoor use on flat, firm terrain. The Convaid Trekker is an attendant propelled device, its intended function and use is to provide mobility to persons with physical disabilities who are frequently or permanently non-ambulatory and limited to a sitting position. In addition the Trekker TR12T and TR14T transit models are for use as seating in a motor vehicle when used in conjunction with an appropriate four-point, strap-type tiedown system per RESNA WC4:2012 section-19.

### Suitable Environment

The chair is intended for both indoor and outdoor use. If the chair is used in the rain, the excess water should be wiped off with a soft cloth. If the chair is splashed with mud or corrosive substances like salt water or road salt, the chair should be washed clean with water, wiped dry and a hypoallergenic and biodegradable lubricant reapplied to the moving parts. Contact with seawater should be avoided, as it will corrode areas that cannot be washed clean. When going from outside to inside, clean any excess dirt or mud from the wheels to prevent soiling of inside environment.

## Safety Instructions

- Follow folding/unfolding instructions.
- Never leave occupied chair unattended.
- Do not attempt to take occupied chair up or down stairs, escalators, steep inclines, icy or slippery surfaces.
- When transferring user to or from chair, apply wheel locks.

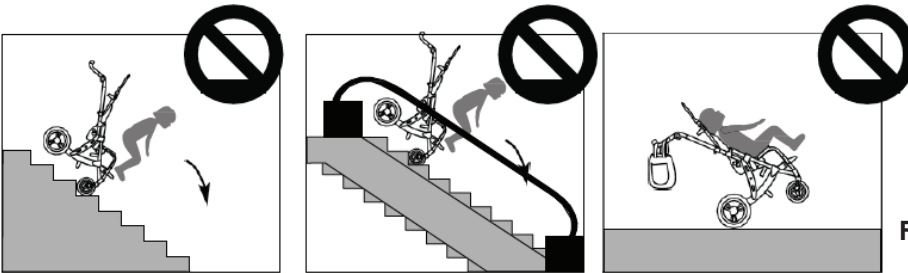


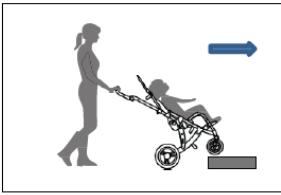
Fig. 207

- To avoid tipping, do not overload the chair, or hang heavy items on the push handles.
- Frequently inspect the adjustments on the mobility base and the positioning accessories. (see maintenance chart)
- Do not use chair after occupant has outgrown it.
- Do not ignore minor malfunctions and maintain the chair in good operating condition. Monitor the wheel locks (brakes) regularly. (See maintenance chart)

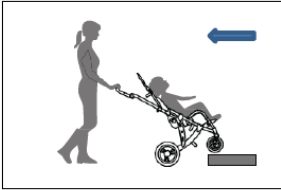
**If and whenever possible and feasible, the rider should transfer out of the chair and into an approved vehicle seat and passenger restraint system.**

However, if a transfer is not possible, use only WC19 or ISO-7176-19 compliant chairs in a moving vehicle which contain the Wheelchair Tiedown and Occupant Restraint Systems (WTORS).

**IMPORTANT INFORMATION**



- When going up a curb or step, face forward and tilt the chair back to lift the front wheels over the curb. Move forward and lift the rear wheels over the curb. The Trekker curb clearance is 7.5" (190mm), the curb clearance with the storage basket is 2.2" (64mm).



- When going down a curb, approach the curb backwards. Lower the rear wheels down the curb and continue backwards, taking the weight off the front wheels so they can be gently lowered.



- Maintain control of the chair at all times while going up/ down ramp. Avoid steep slopes, particularly with a heavy occupant. If in doubt, do not proceed unless a third party is present to help maintain control of chair.

**Fig. 208**

**User Maintenance**

The following maintenance procedures should be conducted on a regular basis: examine your Convaid product visually from time to time for possible wear and tear. Teflon spray\* should be applied to mobility base and moving parts to maintain easy folding and adjustment.

- a) Tire Air Pressure: The air pressure in your pneumatic tires should be checked WEEKLY, since low air pressure may affect brake ability.
- b) Axles and Moving Parts: Axles and moving parts should be wiped off WEEKLY with a slightly moist cloth, to remove dust, dirt and mud. Sparingly apply a high quality Teflon spray\* after each cleaning.
- c) Do Not Use WD-40, silicone sprays or other lubricant sprays as they will attract dust and dirt. Repair or replace loose, worn, bent, missing or damaged parts before using the chair!
- d) Flat tire: In the event of flat tire, please contact customer service or local dealer for specific repairing instructions.

**IMPORTANT INFORMATION**

<b>MAINTENANCE CHART</b>	<b>Weekly</b>	<b>Every 3 months</b>	<b>Every 6 months</b>	<b>As necessary</b>
Rims, tires and tire pressure	•			
Wheel locks	•			
Accessories	•			
Front and rear wheel axles	•			
Cleaning & lubricating all moving parts****	•			
Belts, zippers and Velcro closures		•		
Seat/back upholstery**/tautness		•		
Armrests & foam			•	
Mobility base			•	
Contacting a Convaid Dealer for service or repair***				•

\* Use a non-toxic, hypoallergenic lubricant for all moving parts of the mobility base

\*\* Follow cleaning instructions for appropriate user hygiene

\*\*\* **NOTE:** Repair or replacement of non-removable, worn or broken parts must be performed by a qualified service facility.

\*\*\*\* **NOTE:** Do NOT use WD-40 or other silicone based spray as a lubricant.

**Cleaning and disinfection**

To prevent the spread of germs, clean all skin contacting areas with disinfectant wipes regularly. Keep mobility base dry and apply a non-toxic, hypoallergenic and biodegradable lubricant to all moving parts. After longer storage periods, and before further use, the entire chair needs to be serviced, cleaned, and disinfected.

**Cleaning of mobility base**

Mobility base is to be kept dry and free of dirt and should be wiped off with a non-toxic, hypoallergenic and biodegradable wipe. Lubricant should be applied to moving parts as needed to maintain easy folding and adjustment.

Corrosive substance such as salt water should be avoided at all times. If exposed the mobility base should be wiped off with a moist towel as soon as possible. Water and a soft cloth are sufficient for basic cleaning.

**Cleaning of wheels and brakes**

Wheels and locks should be kept free of dirt or mud after each use. Foreign objects could cause interference with moving parts. Wipe wheels and locks with a moist cloth as needed.

## IMPORTANT INFORMATION

---

### Cleaning of fabric cover

Seat and back upholstery can be easily removed, washed, air dried and reattached to the chair. Use standard detergent to wash fabric.

Cushioned parts can also be removed from chair, washed or wiped off with a moist cloth. Before reattaching them to the chair, make sure they are completely dry. Use mild detergent to wash fabric. Use gentle cycle and cold water. Hang Dry.

Parts that are permanently attached may be wiped thoroughly with a moist cloth. Allow sufficient time to dry before placing user in chair.



### Storage

Store your chair in a clean, dry area and avoid extended exposure to heat or moisture. After extended storage periods, and before reuse, the entire chair needs to be serviced, cleaned and disinfected.

### Re-use

Your Convaid chair should undergo wipe-down disinfection before re-use. Please use a non-toxic, biodegradable disinfectant solution suitable for surface disinfection. Please check the following components for intactness before operation (see MAINTENANCE CHART)

Repair or replace if necessary:

Wheels (tread pattern), air pressure if applicable

- Mobility base
- Seat and back upholstery
- Wheel lock operation
- Bearings and axles: check wear and tear/ lubrication
- Straight-running stability of wheels attachments

### Repairs

**User:** The user can replace easily removable parts or accessories, e.g. foot supports, heel loops, all fabric items, hand grips, etc.

**Manufacturer/Service Facility:** Repair or replacement of permanently attached, worn or broken parts must be performed by a qualified service facility. Any individual part of the chair can be replaced. Contact the manufacturer/service facility for needed repairs. The chair should be packaged in the original or suitable shipping carton for return to the manufacturer/service facility. Ship via UPS.



**IMPORTANT INFORMATION****Tools Required**

3/8", 7/16", 3/8" or 2 adjustable wrenches with 3/4" capacity, Phillips head screwdriver 5/32"  
Allen wrench (included)

**Spare Parts**

If you need any spare parts for your chair, please visit or call your Convoid Service Dealer you purchased this chair from. If the part is not under warranty, you will receive an estimate of the cost and, if necessary, shipping instructions for the return of the chair for repairs.

**Functional Tests**

All four wheels should make contact with the floor. With the chair empty, push it forward on a smooth level surface with enough momentum to travel six feet (2 m). The chair should not veer to the left or right more than six inches (150 mm). Wheels should be free running. Following the fold/unfold instructions; the chair should fold/unfold smoothly without undue effort. All fasteners should be secure. Fasteners on moving joints should not be over tight. Seat fabric should not be wide-stretched or sagging. Positioning accessories should be correctly adjusted and secure.

Convoid Service Dealer

Please record the Convoid Dealer from which you purchased your chair:

Company: \_\_\_\_\_

Address: \_\_\_\_\_

Phone: \_\_\_\_\_ Website: \_\_\_\_\_

Contact: \_\_\_\_\_ Email: \_\_\_\_\_

Serial #: \_\_\_\_\_

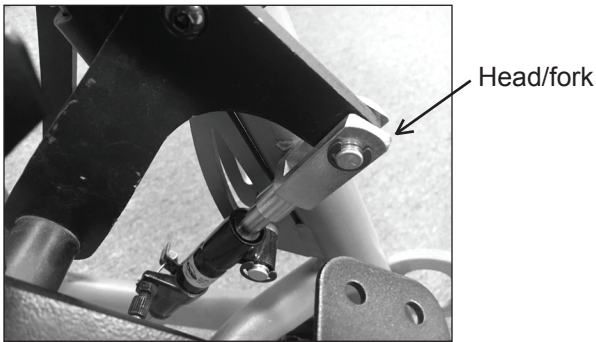
Or contact Convoid Customer Service at  
844 US Mobility (844-876-6245) (+1-310-618-0111) or  
convoidsales.us@etac.com

# Troubleshooting Guide

## Trekker Mechlock Assembly

**⚠ WARNING:** The Trekker Mecklock head/fork should be tightly torqued onto the Mecklock shaft. If not properly tightened, the head/fork assembly may become unscrewed. **Fig. 209**

**⚠ WARNING:** Do not adjust mecklock as this will affect intended functionality. **Fig. 210**



**Fig. 209**



**Fig. 210** Adjustment Barrel

# Tilt Adjustment Lever Handle



Fig. 211



Fig. 212

- 1. Plug the cable end into the adjustment barrel. Make sure the chrome cable end is fully seated inside adjustment barrel.

**!** **WARNING:** The cable on the tilt adjustment lever may be pulled loose or dislodged during transport and/or initial assembly. Please check the following cable position.

.....

## Limited Warranty

Convoid warrants to the original retail purchaser of the Convoid product, that if any part thereof proves functionally defective in material or workmanship within the specified warranty period, such defective part will be repaired or replaced (at Convoid's discretion) free of charge. Warranty service may be performed by Convoid service center or (at Convoid's discretion) the factory.

### Warranty Period

Mobility base .....Lifetime of original retail buyer  
Other components .....One year  
Fabric & webbing.....One year

This warranty does not cover normal wear and tear or damage caused by accident or misuse. To exercise this limited warranty, the user should first obtain a Return Authorization Number from Convoid's customer service. The product must be delivered charges pre-paid (UPS recommended) to the factory or to an authorized service center, together with a copy of the original invoice, the Return Authorization Number and a written description of the problem.

THIS LIMITED WARRANTY EXCLUDES ANY CLAIM FOR INCIDENTAL OR CONSEQUENTIAL DAMAGES. ANY IMPLIED WARRANTY APPLICABLE IS LIMITED TO THE DURATION OF THIS WRITTEN WARRANTY. SOME STATES DO NOT ALLOW THE EXCLUSION OR LIMITATIONS OF INCIDENTAL OR CONSEQUENTIAL DAMAGES OR LIMITATIONS ON HOW LONG AN IMPLIED WARRANTY LASTS, SO THE ABOVE LIMITATIONS OR EXCLUSIONS MAY NOT APPLY TO THE USER. THERE ARE NO WARRANTIES WHICH EXTEND BEYOND THE DESCRIPTION ON THE FACE THEREOF. This warranty gives the user specific legal rights and the user may have other rights that vary from state to state. Warranty applicable in USA only, may vary in other countries.

.....

2830 California Street, Torrance, CA 90503, USA  
**Toll free in the US:** 1-844-US-Mobility (844-876-6245)  
**Phone:** (310) 618-0111  
**Fax:** (310) 618-8811  
**Email:** [convoidsales.us@etac.com](mailto:convoidsales.us@etac.com)  
**International Email:** [international.convoid.us@etac.com](mailto:international.convoid.us@etac.com)  
[www.etac.us.com](http://www.etac.us.com)

